



ASSEMBLY INSTRUCTIONS
COASTER FINE FURNITURE



Fine Furniture for every stage of life

202091KE (B1&B2)
Eastern King Bed

REVISION 0 : 11/26/2013
REVISION 1 : 08/28/2018
REVISION 2 : 01/02/2019
REVISION 3 : 07/05/2019

ITEM: 202091KE (B1&B2)



ASSEMBLY INSTRUCTIONS

ASSEMBLY TIPS:

1. Remove hardware from box and sort by size.
2. Please check to see that all hardware and parts are present prior to start of assembly.
3. Please follow attached instructions in the same sequence as numbered to assure fast & easy assembly.



WARNING!

1. Don't attempt to repair or modify parts that are broken or defective. Please contact the store immediately.
2. This product is for home use only and not intended for commercial establishments.







ASSEMBLY TIME

20 MINUTES

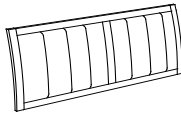
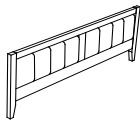
PARTS IDENTIFICATION

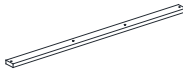
B1 (BOX 1)



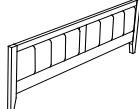
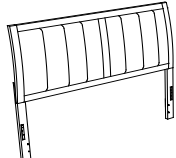

<p>A HEADBOARD PANEL</p>  <p>1PC</p>	<p>D FOOTBOARD</p>  <p>1PC</p>
<p>B RIGHT HEADBOARD LEG</p>  <p>1PC</p>	<p>E BED SLAT</p>  <p>4PCS</p>
<p>C LEFT HEADBOARD LEG</p>  <p>1PC</p>	<p>F BED SLAT SUPPORT WITH LEVELER</p>  <p>8PCS</p>

B2 (BOX 2)

<p>G BED RAIL</p>  <p>2PCS</p>	<p>D 202091KE(B1) FROM BOX 1 FOOTBOARD</p>  <p>1PC</p>
<p>HB 202091KE(B1) FROM BOX 1 HEADBOARD COMPLETE</p>  <p>1PC</p>	

HARDWARE IDENTIFICATION

Z-B1 (BOX 1) - HARDWARE PACK IS LOCATED IN 202091KE (B1)

<p>1 BOLT (M6 x 35mm - BLK)</p>  <p>6PCS</p>	<p>4 ALLEN WRENCH (M4 x 60mm - BLK)</p>  <p>1PC</p>
<p>2 LOCK WASHER (1/4" - BLK)</p>  <p>6PCS</p>	<p>5 FLAT HEAD SCREW (M4 x 32mm - RBW)</p>  <p>8PCS</p>
<p>3 FLAT WASHER (1/4"ID x 13mm - BLK)</p>  <p>6PCS</p>	

NOTE:

Phillips head screw driver is required in the assembly process; however, manufacturer does not provide this item.

ASSEMBLY INSTRUCTIONS

STEP 1

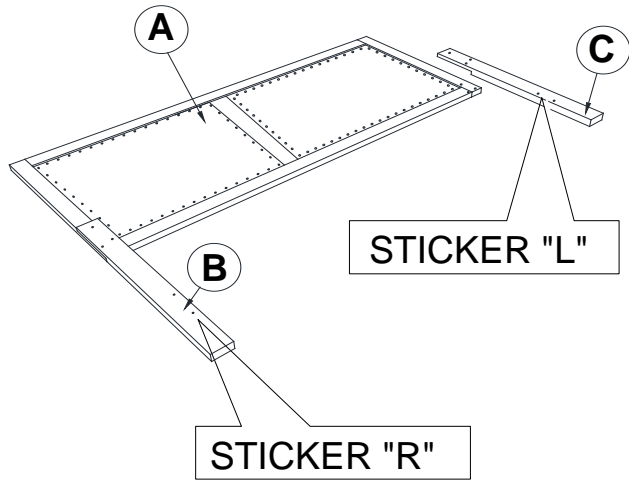

****BACK VIEW****

Note: Please take note of the marking sticker (L & R) on the headboard legs.

STEP 2

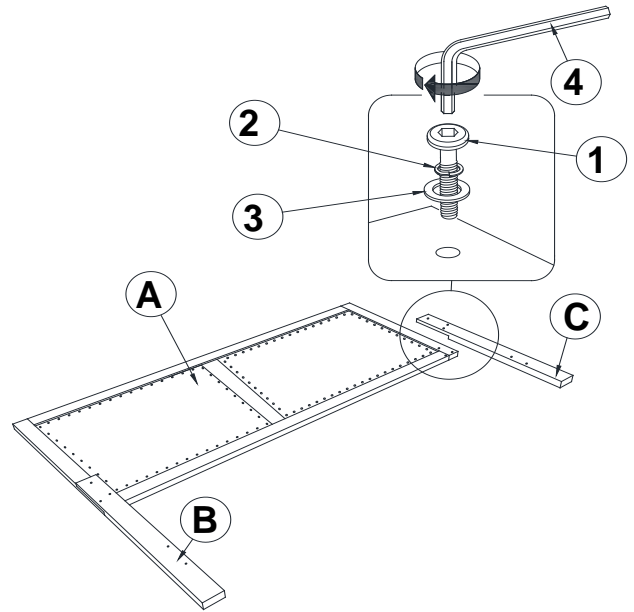

****BACK VIEW****

STEP 3

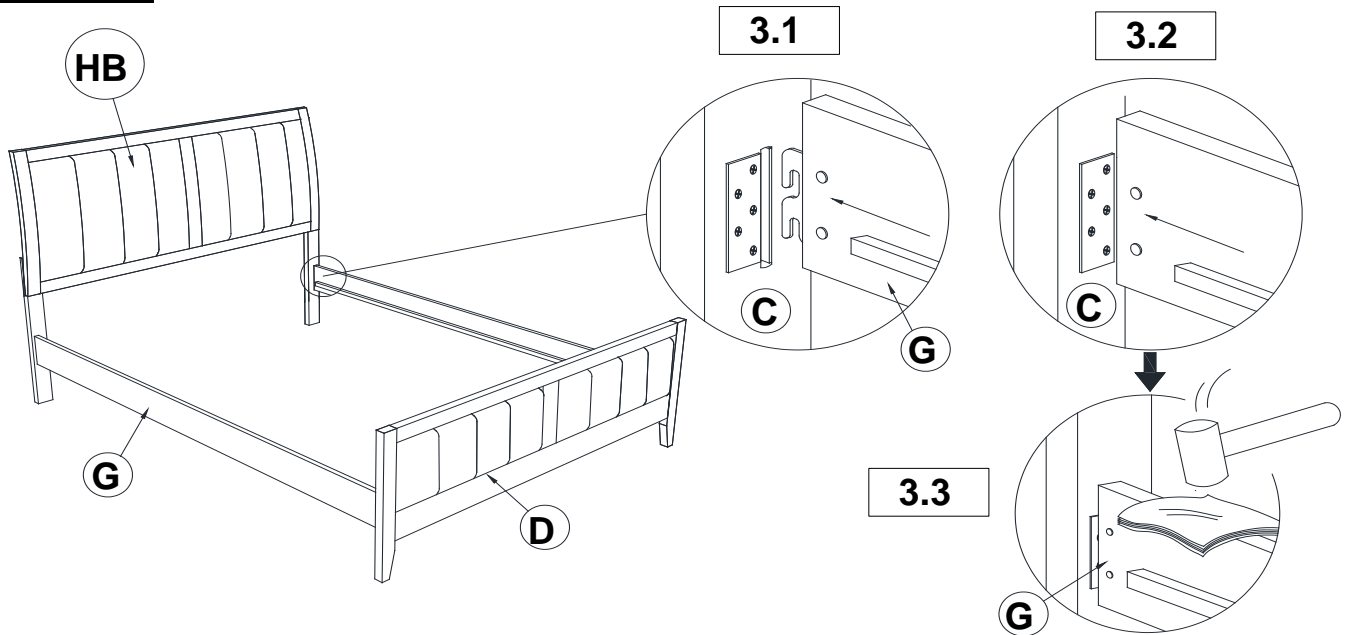

ASSEMBLY INSTRUCTIONS

STEP 4

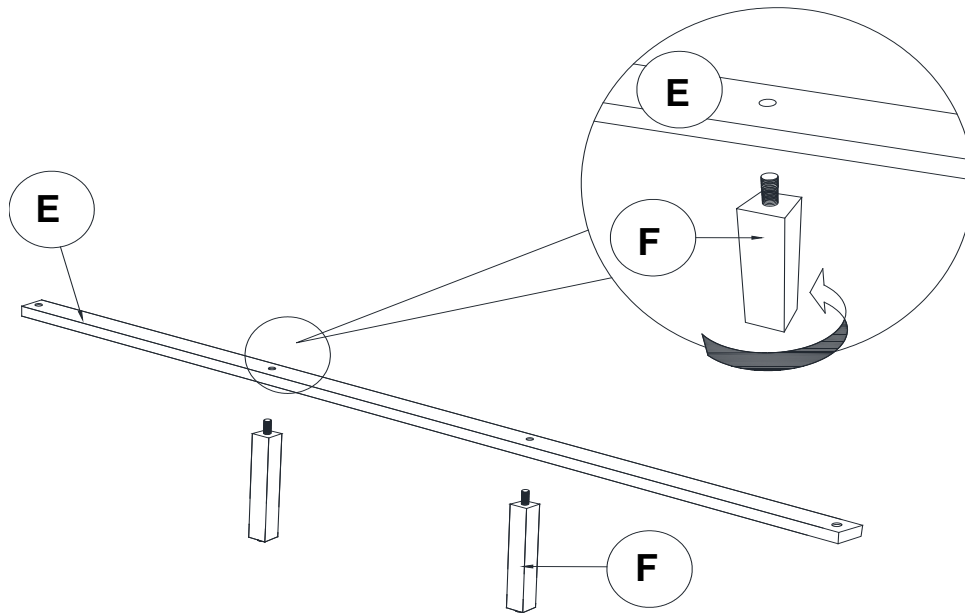

STEP 5

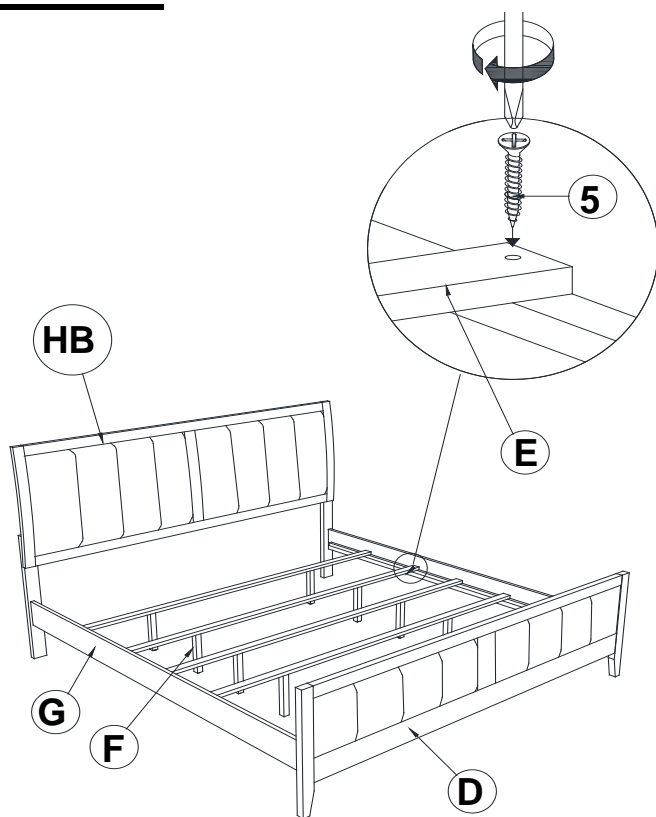

STEP 6
COMPLETE

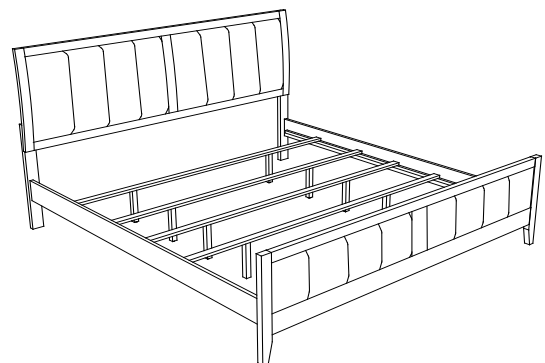

ITEM: 202091KE (B1&B2)



Inner Size : 76.75"W x 81.00"D

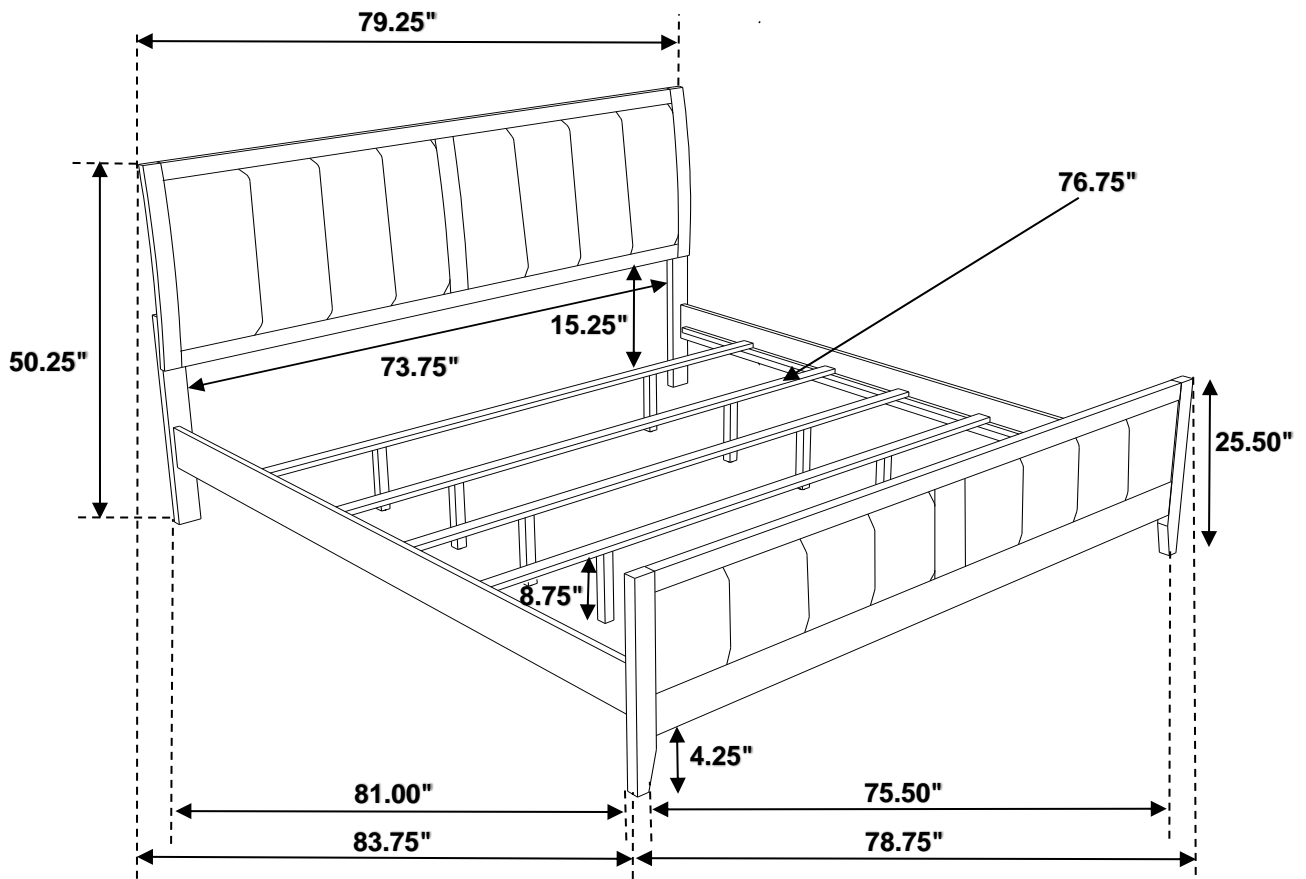

Note: Dimension tolerance $\pm 5\%$