

*ASSEMBLY INSTRUCTIONS*  
*COASTER FINE FURNITURE*



*Fine Furniture for every stage of life*

**202091F(B1 & B2)**  
***Full Bed***

# ITEM: 202091F (B1&B2)



## ASSEMBLY INSTRUCTIONS

### ASSEMBLY TIPS:

1. Remove hardware from box and sort by size.
2. Please check to see that all hardware and parts are present prior to start of assembly.
3. Please follow attached instructions in the same sequence as numbered to assure fast & easy assembly.



### WARNING!

1. Don't attempt to repair or modify parts that are broken or defective. Please contact the store immediately.
2. This product is for home use only and not intended for commercial establishments.







ASSEMBLY TIME

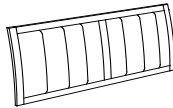
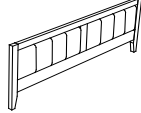

20 MINUTES

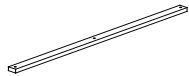
## PARTS IDENTIFICATION

### B1 ( BOX 1)



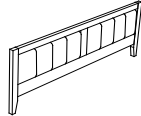

A	HEADBOARD PANEL		1PC	D	FOOTBOARD		1PC
B	RIGHT HEADBOARD LEG		1PC	E	BED SLAT		4PCS
C	LEFT HEADBOARD LEG		1PC	F	BED SLAT SUPPORT WITH LEVELER		4PCS

### B2 ( BOX 2)

G	BED RAIL		2PCS	D	202091F(B1) FROM BOX 1 FOOTBOARD		1PC
HB	2020911F(B1) FROM BOX 1 HEADBOARD COMPLETE		1PC				

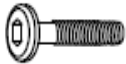
## HARDWARE IDENTIFICATION

### Z-B1 (BOX 1) - HARDWARE PACK IS LOCATED IN 202091F (B1)

1	BOLT (M6 x 35mm - BLK)		6PCS	4	ALLEN WRENCH (M4 x 60mm - BLK)		1PC
2	LOCK WASHER (1/4" - BLK)		6PCS	5	FLAT HEAD SCREW (M4 x 32mm - RBW)		8PCS
3	FLAT WASHER (1/4"ID x 13mm - BLK)		6PCS				

### NOTE:

Phillips head screw driver is required in the assembly process; however, manufacturer does not provide this item.

**ASSEMBLY INSTRUCTIONS**

**STEP 1**

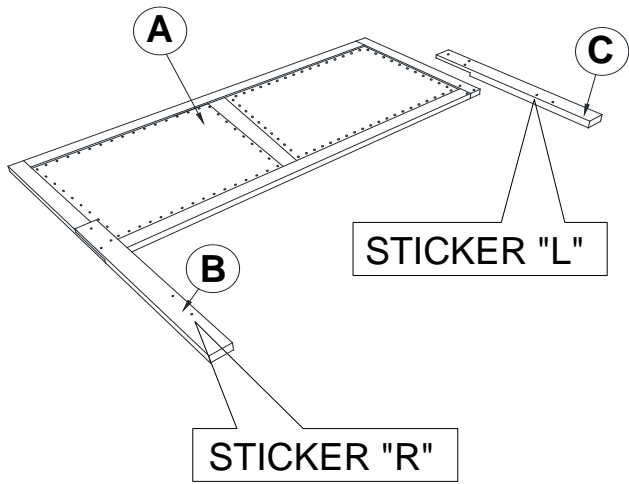

**\*\*BACK VIEW\*\***

Note: Please take note of the marking sticker (L & R) on the headboard legs.

**STEP 2**

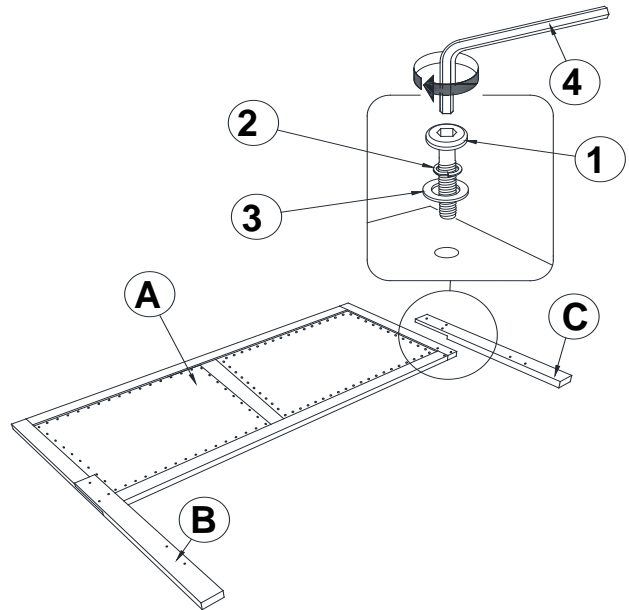

**\*\*BACK VIEW\*\***

**STEP 3**

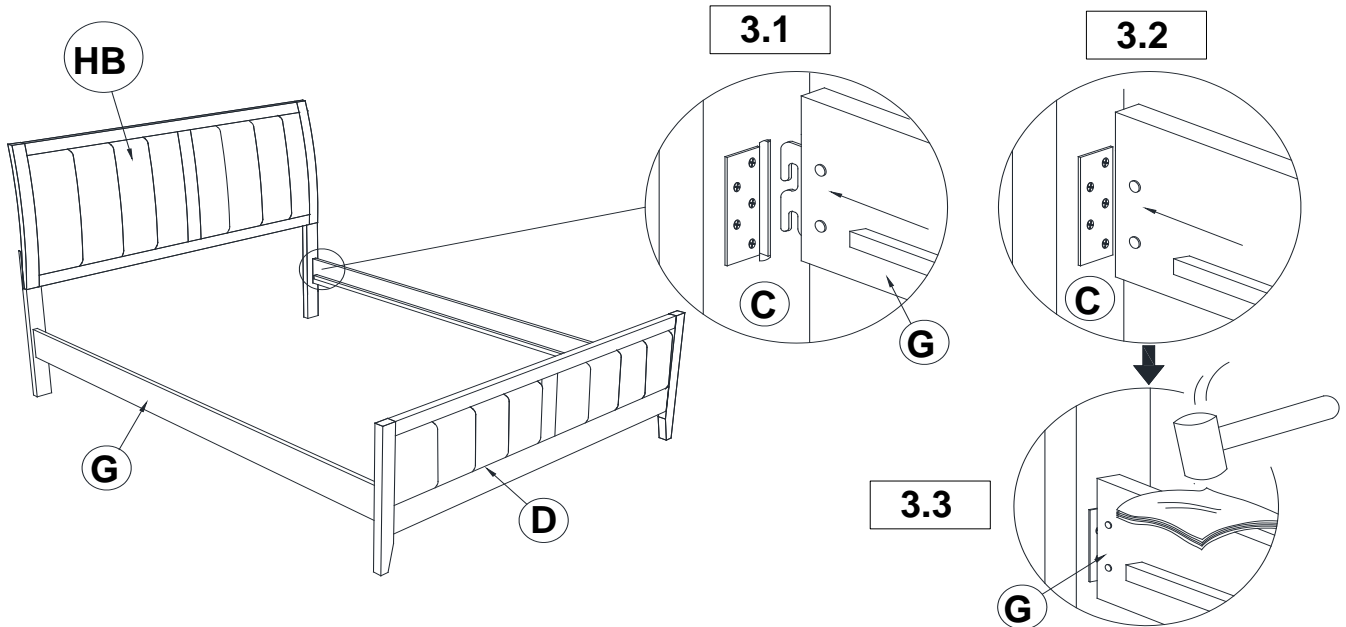

# ITEM: 202091F (B1&B2)



## ASSEMBLY INSTRUCTIONS

### STEP 4

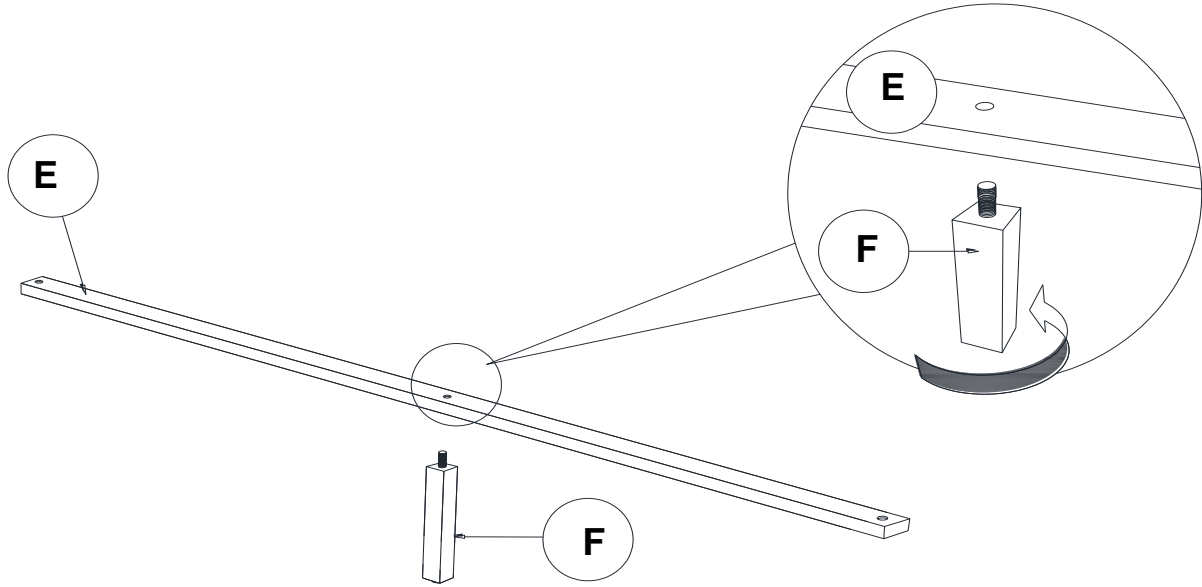

### STEP 5

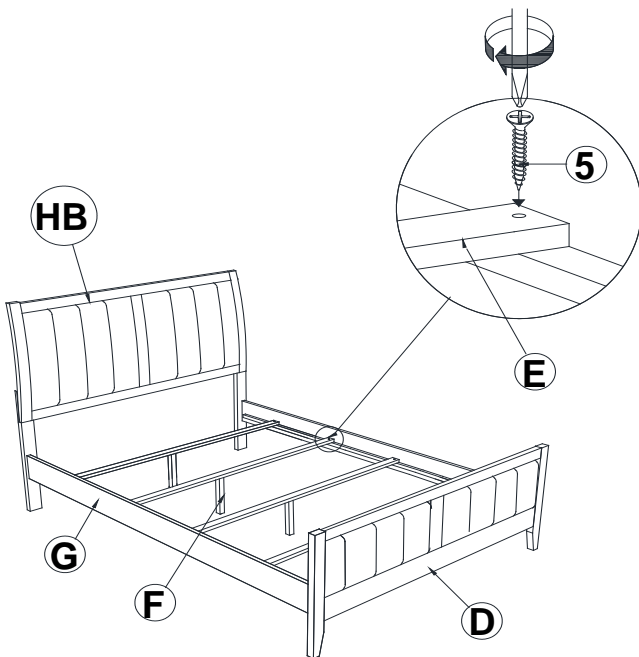

### STEP 6 **COMPLETE**

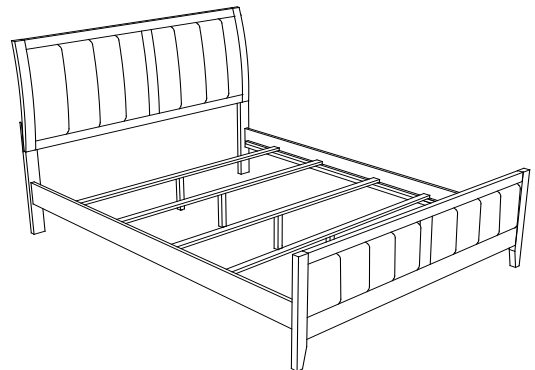

# ITEM: 202091F (B1&B2)



Inner Size : 54.50"W x 76.00"D

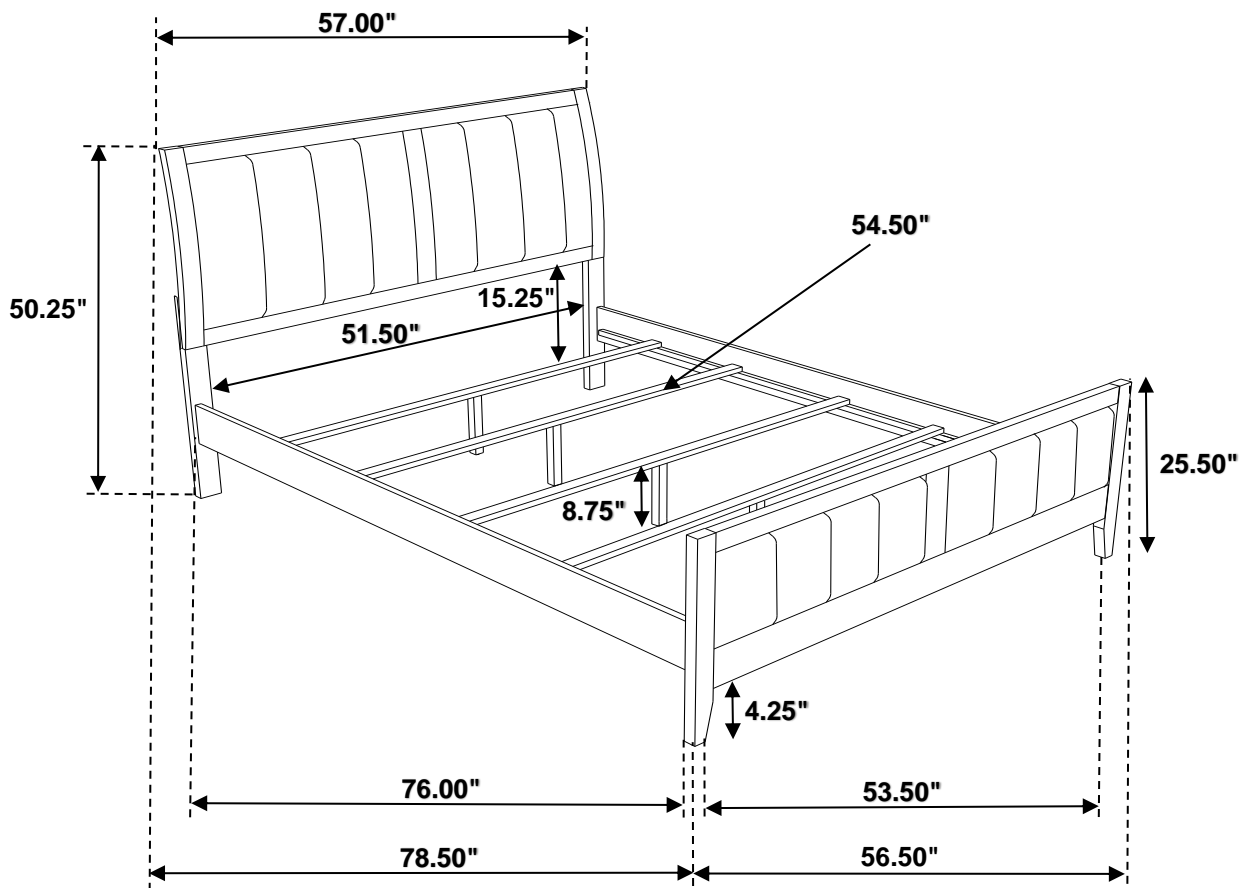

Note: Dimension tolerance  $\pm 5\%$