

ASSEMBLY INSTRUCTIONS
COASTER FINE FURNITURE

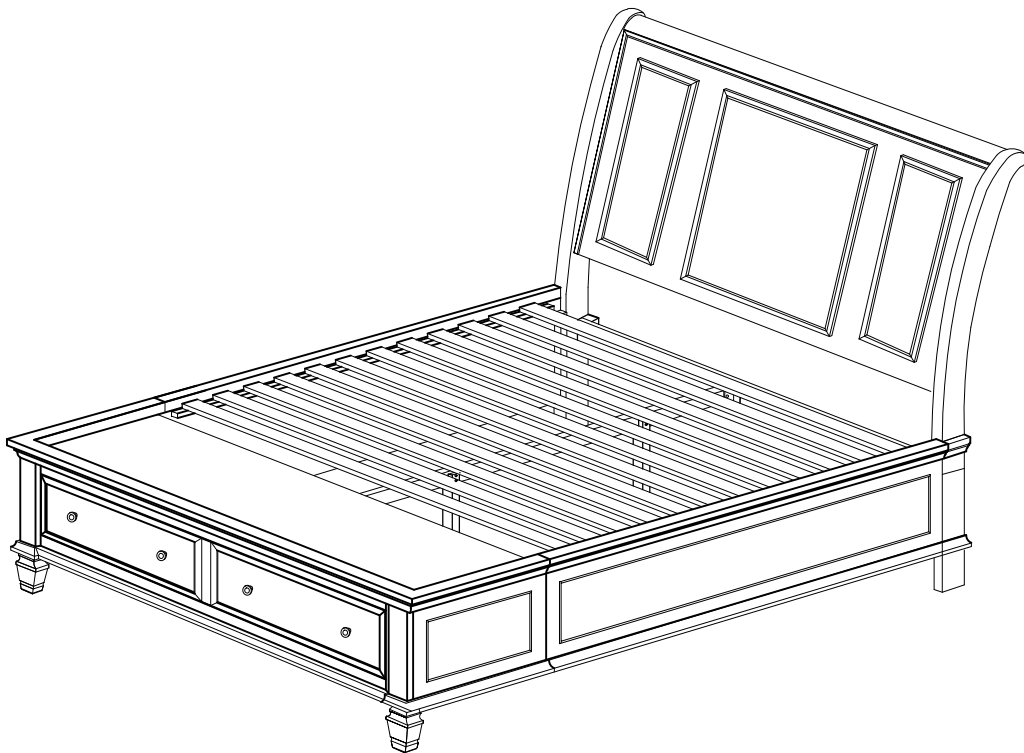

Fine Furniture for every stage of life

201309KW (B1-B3)
California King Storage Bed

REVISION 0 : 06/03/2011
REVISION 1 : 09/27/2011
REVISION 2 : 07/17/2012
REVISION 3 : 08/29/2012
REVISION 4 : 11/28/2012
REVISION 5 : 03/17/2016
REVISION 6 : 08/14/2018
REVISION 7 : 10/17/2019
REVISION 8 : 08/06/2020

ITEM: 201309KW (B1-B3)



ASSEMBLY INSTRUCTIONS

ASSEMBLY TIPS:

1. Remove hardware from box and sort by size.
2. Please check to see that all hardware and parts are present prior to start of assembly.
3. Please follow attached instructions in the same sequence as numbered to assure fast & easy assembly.



WARNING!

1. Don't attempt to repair or modify parts that are broken or defective. Please contact the store immediately.
2. This product is for home use only and not intended for commercial establishments.

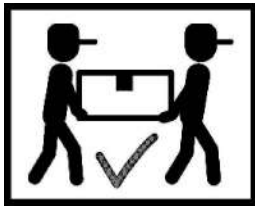

ASSEMBLY TIME

35 MINUTES

PARTS IDENTIFICATION

B1 (BOX 1)

A HEADBOARD PANEL



1PC

B1 LEFT HEADBOARD LEG



1PC

B2 RIGHT HEADBOARD LEG



1PC

H HEADBOARD BOTTOM RAIL



1PC

B2 (BOX 2)

C STORAGE FOOTBOARD

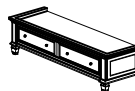

1PC

E CENTER RAIL SUPPORT WITH LEVELER



2PCS

F CENTER RAIL

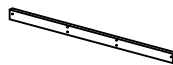

1PC

G ROLL SLAT
(12PCS)

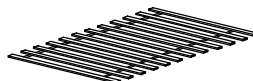

1 SET

B3 (BOX 3)

D1 LEFT BED RAIL



1PC

D2 RIGHT BED RAIL



1PC

HB 201309KW (B1)
FROM BOX 1
HEADBOARD COMPLETE



1PC

C 201309KW (B2)
FROM BOX 2
STORAGE FOOTBOARD

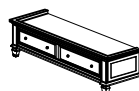

1PC

ITEM: 201309KW (B1-B3)



ASSEMBLY INSTRUCTIONS

ASSEMBLY TIPS:

1. Remove hardware from box and sort by size.
2. Please check to see that all hardware and parts are present prior to start of assembly.
3. Please follow attached instructions in the same sequence as numbered to assure fast & easy assembly.







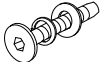

WARNING!

1. Don't attempt to repair or modify parts that are broken or defective. Please contact the store immediately.
2. This product is for home use only and not intended for commercial establishments.

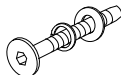
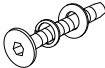
HARDWARE IDENTIFICATION

Z-B1 (BOX 1) - HARDWARE PACK IS LOCATED IN 201309KW (B1)

1	ALLEN WRENCH (M4 x 110mm - BLK)		1PC
2	SHORT BOLT (M6 x 35mm - BLK)		8PCS
3	WOOD DOWEL (M8 x 30mm)		12PCS
4	LONG FLAT HEAD SCREW (#8 x 1 1/8" - BLK)		24PCS
5	LONG BOLT (M6 x 60mm - BLK)		10PCS
6	MEDIUM BOLT (M6 x 45mm - BLK)		6PCS
7	SHORT FLAT HEAD SCREW (M4 x 20mm - BLK)		8PCS
8	WRENCH (2 x 24.5 x 85 - RBW)		1PC
9	HEX NUT (M6 - RBW)		2PCS
10	U BRACKET (26 x 63 x 70mm - RBW)		2PCS

NOTE:

Phillips head screw driver is required in the assembly process; however, manufacturer does not provide this item.

ITEM: 201309KW (B1-B3)



ASSEMBLY INSTRUCTIONS

STEP 1

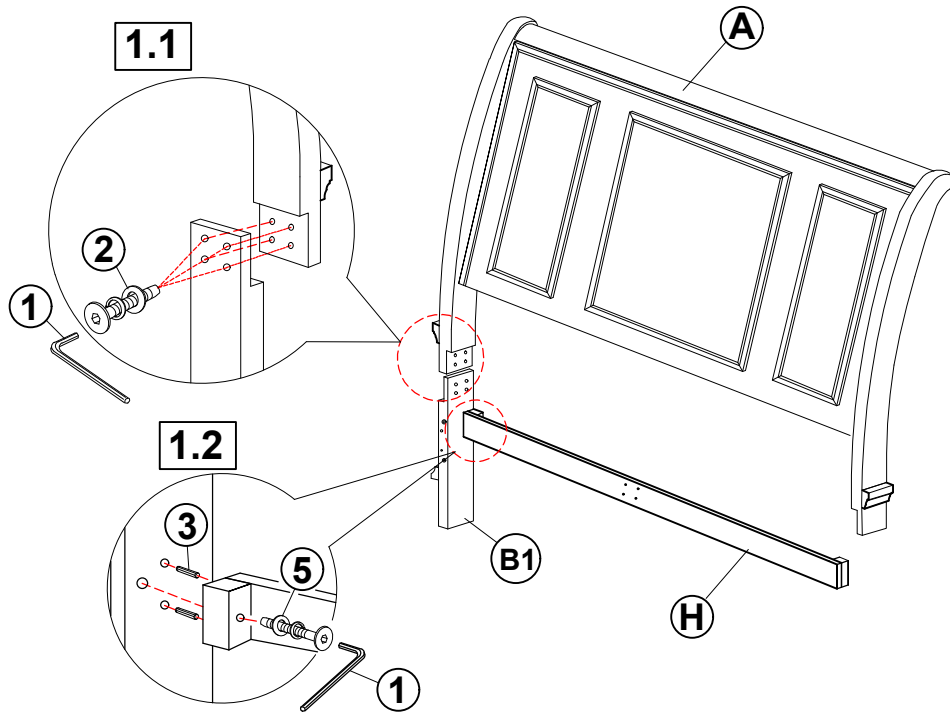

STEP 2

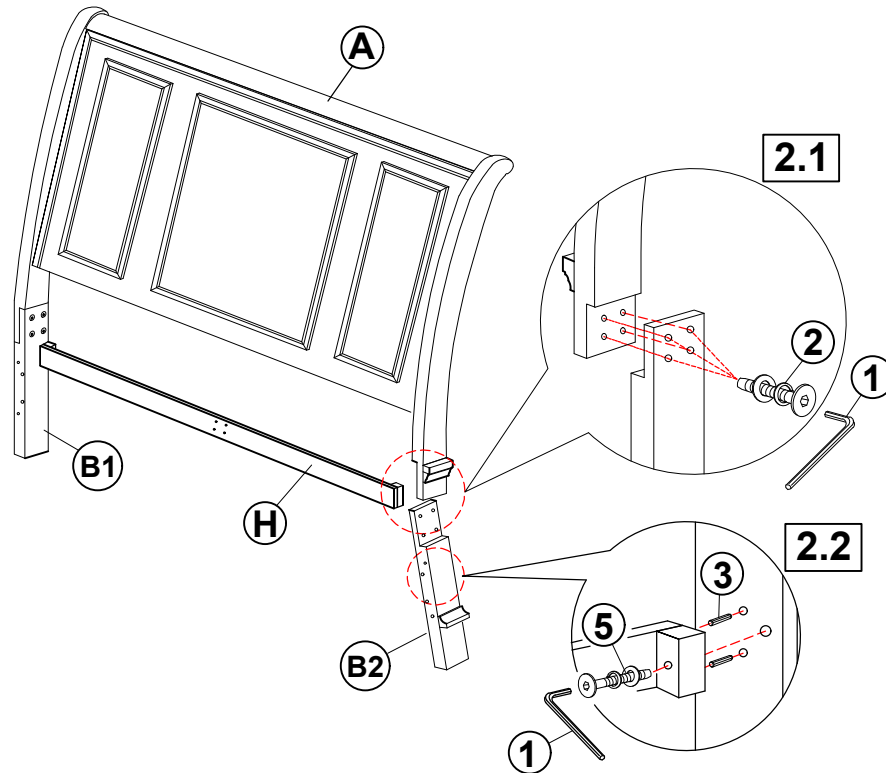

ITEM: 201309KW (B1-B3)

ASSEMBLY INSTRUCTIONS

STEP 3

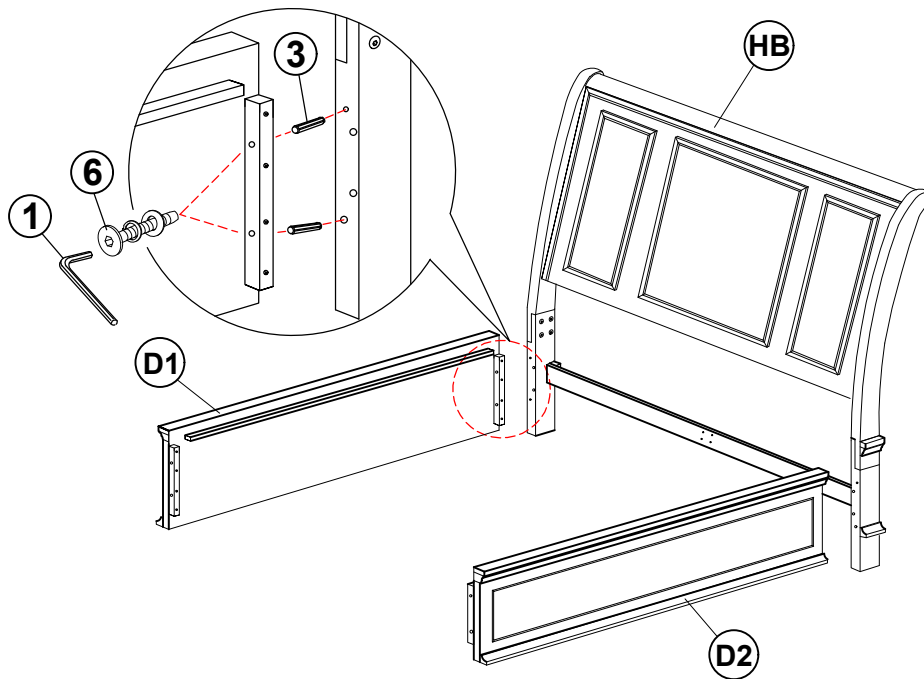

STEP 4

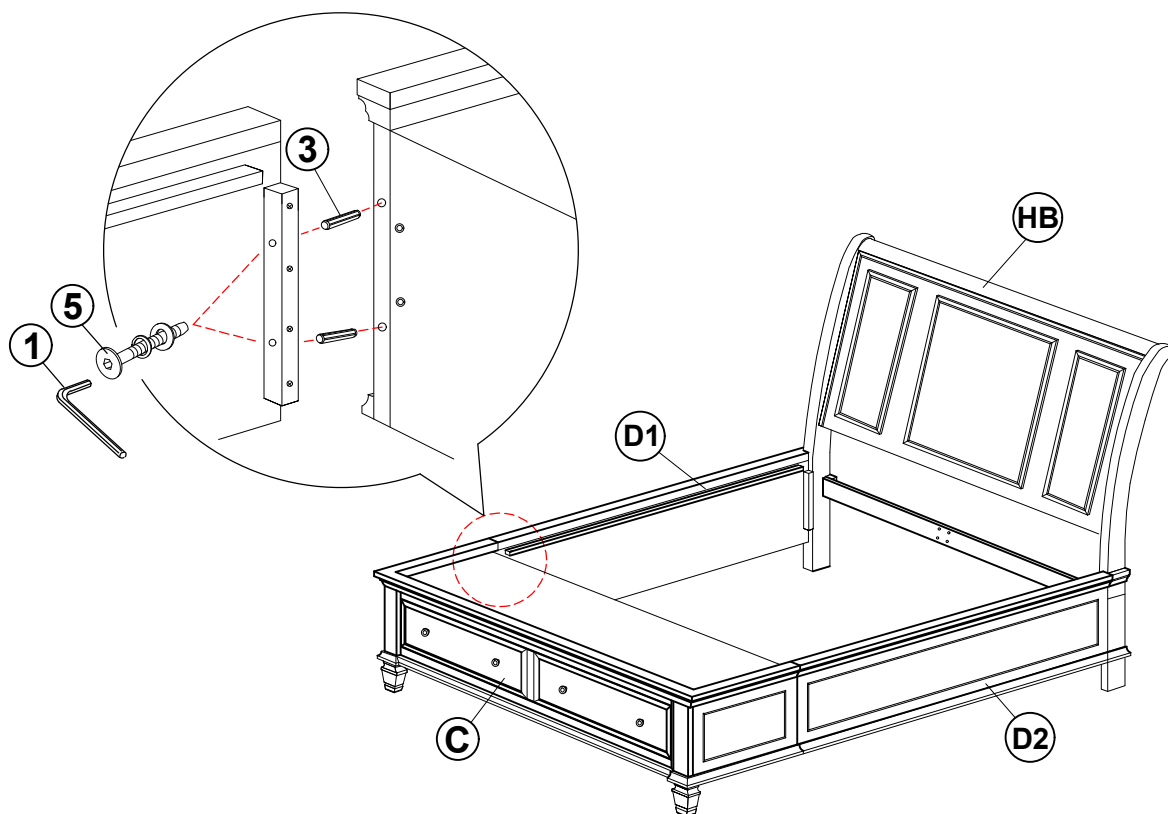

ITEM: 201309KW (B1-B3)



ASSEMBLY INSTRUCTIONS
STEP 5

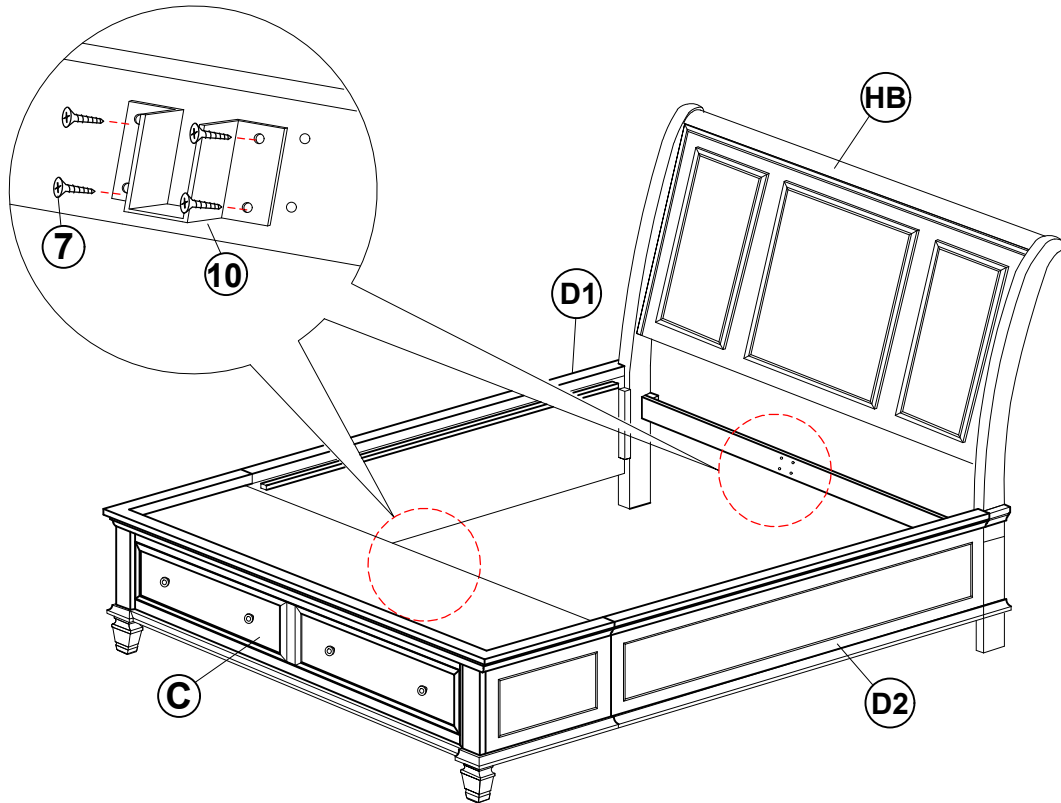

STEP 6

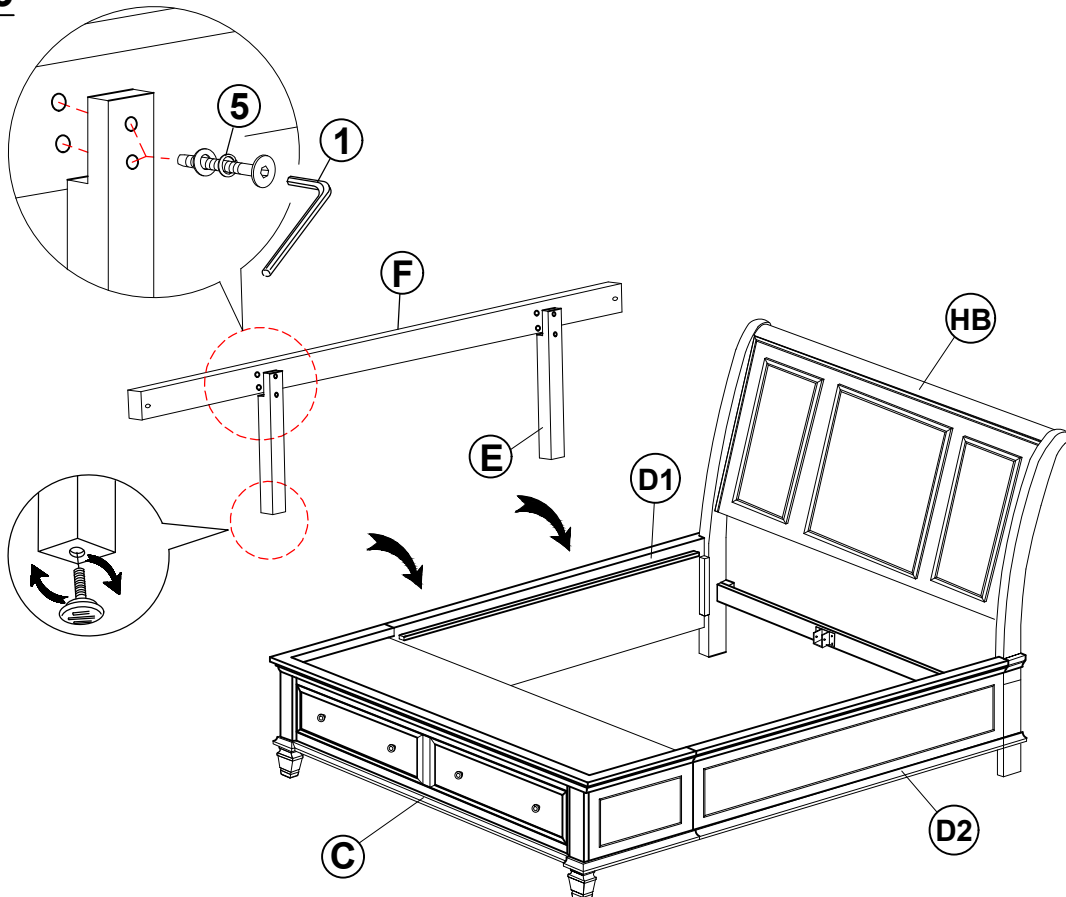

ITEM: 201309KW (B1-B3)



ASSEMBLY INSTRUCTIONS
STEP 7

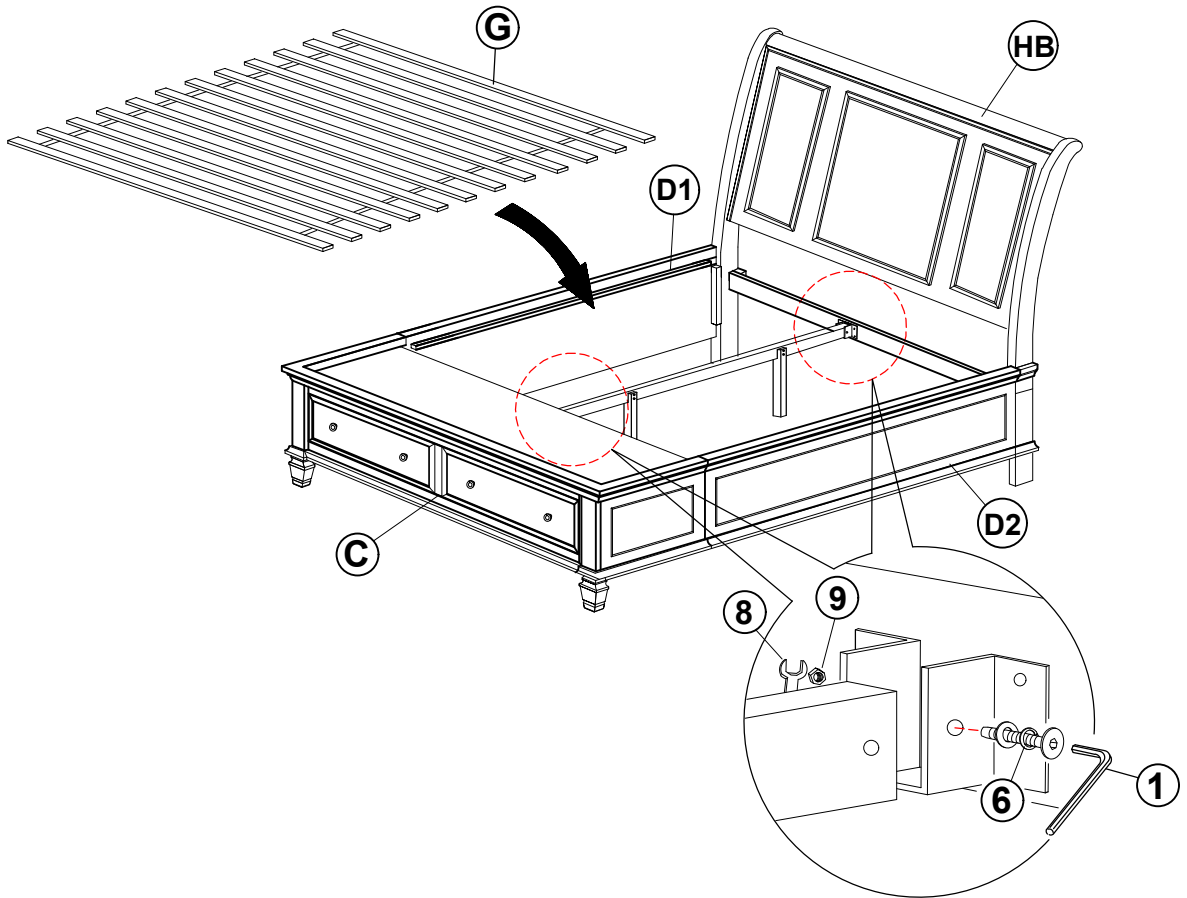

STEP 8

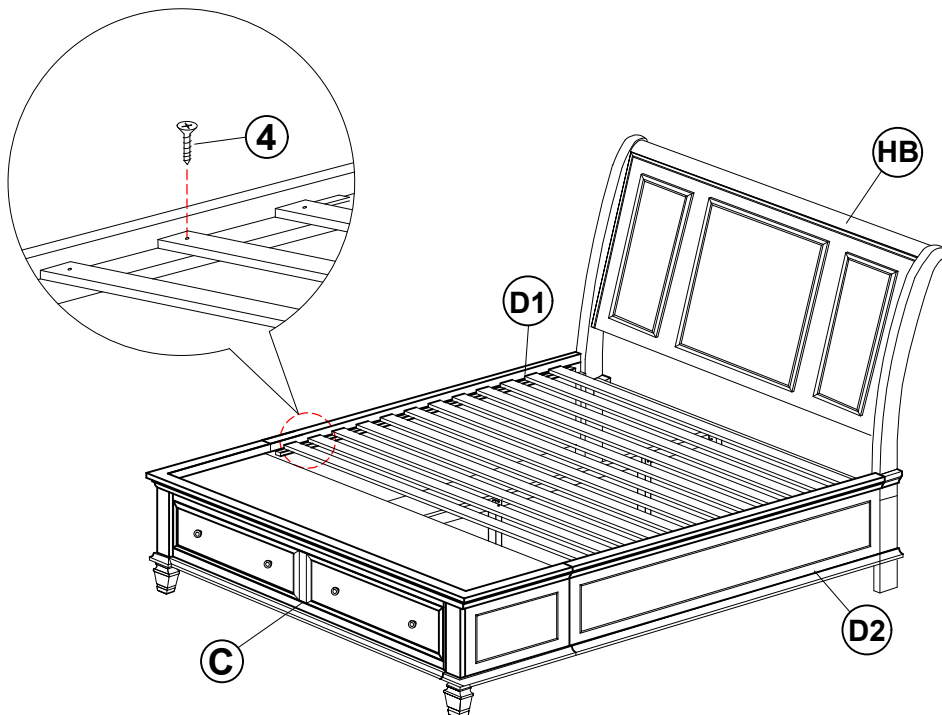

ITEM: **201309KW (B1-B3)**



ASSEMBLY INSTRUCTIONS

STEP 9

COMPLETE

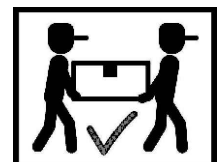
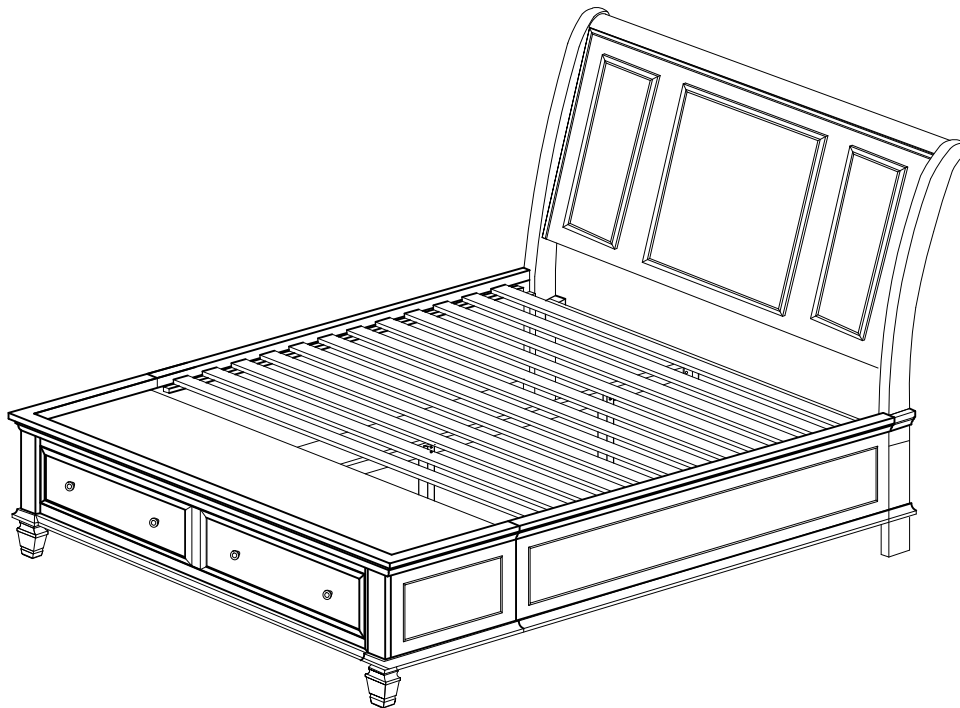

ITEM: **201309KW (B1-B3)**



Inner Size : 72.00"W X 85.00"D

Inner Size of Drawer : 31.00"W X 14.75"D X 5.50"H X 0.25"T

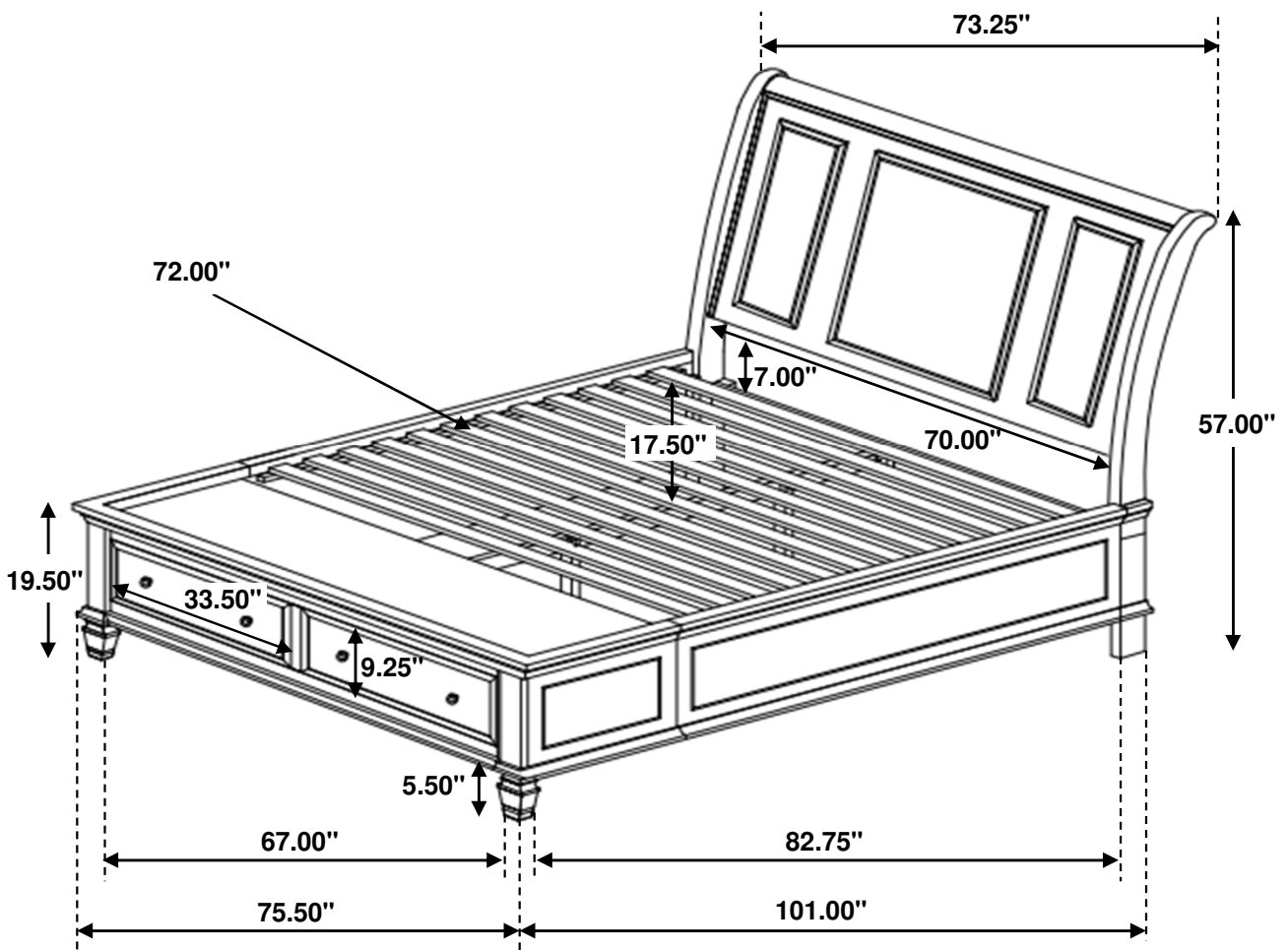

Note : Dimension tolerance $\pm 5\%$