



ASSEMBLY INSTRUCTIONS
COASTER FINE FURNITURE



Fine Furniture for every stage of life

182724
4 PC COUNTER HT DINING SET

REVISION 0 : 12/21/2023

PAGE 1 OF 14

COASTERFURNITURE.COM

ITEM:182724



ASSEMBLY INSTRUCTIONS

ASSEMBLY TIPS:

1. Remove hardware from box and sort by size.
2. Please check to see that all hardware and parts are present prior to start of assembly.
3. Please follow attached instructions in the same sequence as numbered to assure fast & easy assembly.



WARNING!

1. Don't attempt to repair or modify parts that are broken or defective. Please contact the store immediately.
2. This product is for home use only and not intended for commercial establishments.

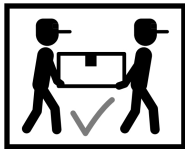

ASSEMBLY TIME 95 MINUTES

PARTS IDENTIFICATION

A LARGE TOP PANEL

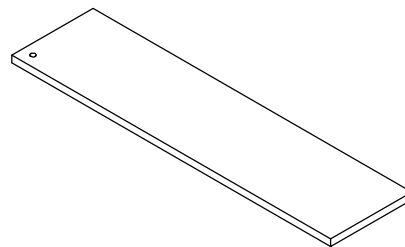

1PC

B LARGE LEFT FRAME



1PC

C LARGE RIGHT FRAME

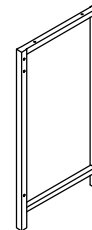

1PC

D LARGE TOP CROSSBAR

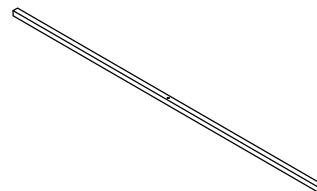

1PC

E LARGE BOTTOM CROSSBAR

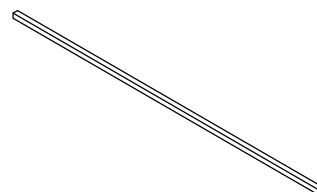

1PC

ITEM:182724

ASSEMBLY INSTRUCTIONS

PARTS IDENTIFICATION



F LARGE BACK FRAME 1PC

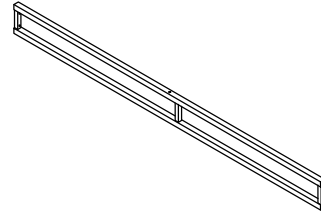

G SMALL TOP PANEL 1PC

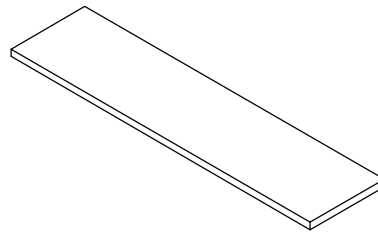

H SMALL LEFT FRAME 1PC



I SMALL RIGHT FRAME 1PC

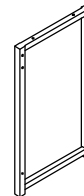

J SMALL TOP CROSSBAR 1PC

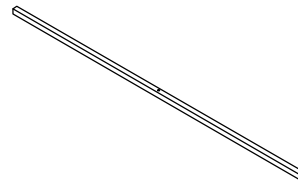

K SMALL BOTTOM CROSSBAR 1PC

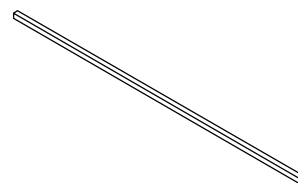

ITEM:182724

ASSEMBLY INSTRUCTIONS

PARTS IDENTIFICATION



L

SMALL BACK FRAME

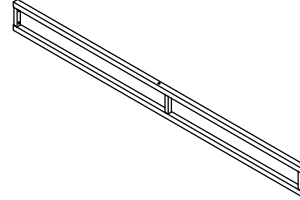

1PC

M

CUSHION SEAT

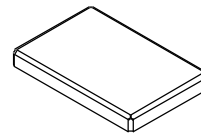

1PC

N

STOOL LEFT FRAME



1PC

O

STOOL RIGHT FRAME



1PC

P

STOOL TOP CROSSBAR

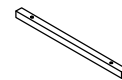

1PC

Q

STOOL BOTTOM CROSSBAR

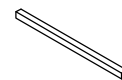

1PC

ITEM:182724

ASSEMBLY INSTRUCTIONS



R STOOL FRONT FRAME

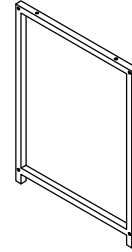

1PC

S USB

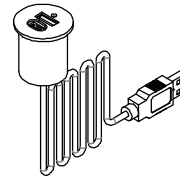

1PC

T WHEEL

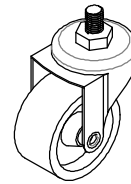

4PCS

Z

HARDWARE IDENTIFICATION

1 SHORT BOLT
(1/4" x 12mm BLK)



4PCS

2 MEDIUM BOLT
(1/4" x 35mm BLK)



28PCS

3 LONG BOLT
(1/4" x 56mm BLK)



8PCS

4 SMALL CAP
(20 x 20mm BLK)



4PCS

5 LARGE CAP
(30 x 30mm BLK)



8PCS

6 COVER



12PCS

7 ALLEN WRENCH
(4mm)



1PC

NOTE:QUANTITIES SHOWN ARE FOR ONE LARGE TABLE, ONE SMALL TABLE AND ONE STOOL

ITEM:182724



ASSEMBLY INSTRUCTIONS

STEP 1 Do not tighten until each step is completed or instructed.

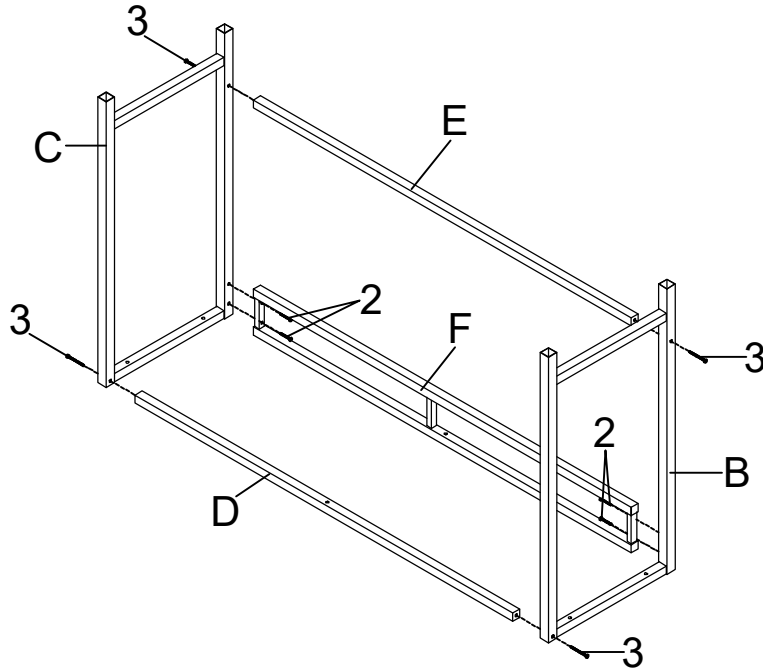

STEP 2

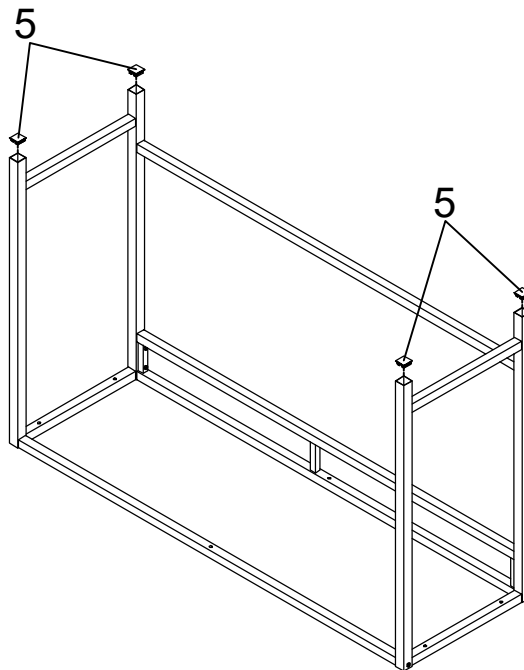

ITEM:182724
ASSEMBLY INSTRUCTIONS
STEP 3



Pay attention to this position

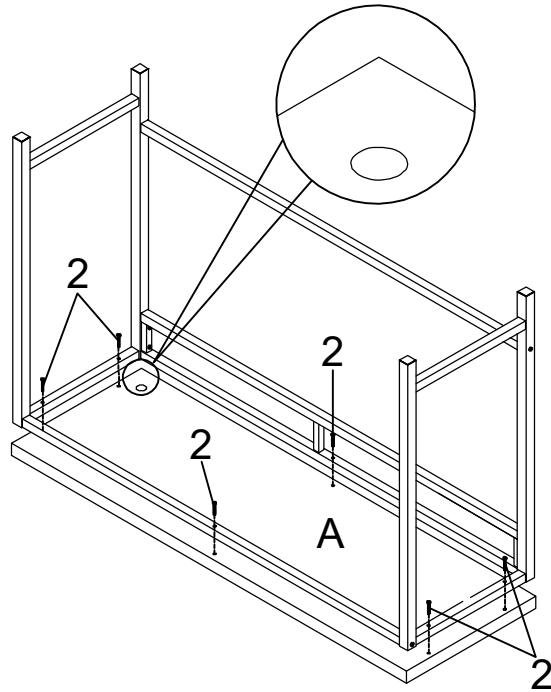

STEP 4

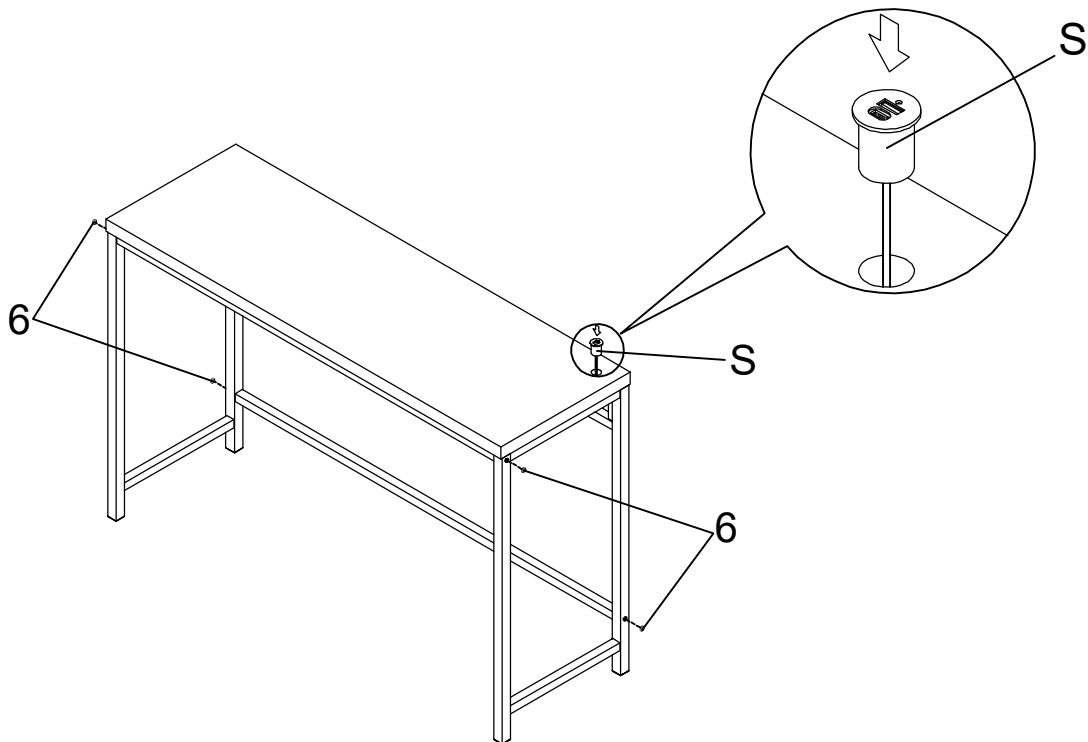

ITEM:182724

ASSEMBLY INSTRUCTIONS

STEP 5

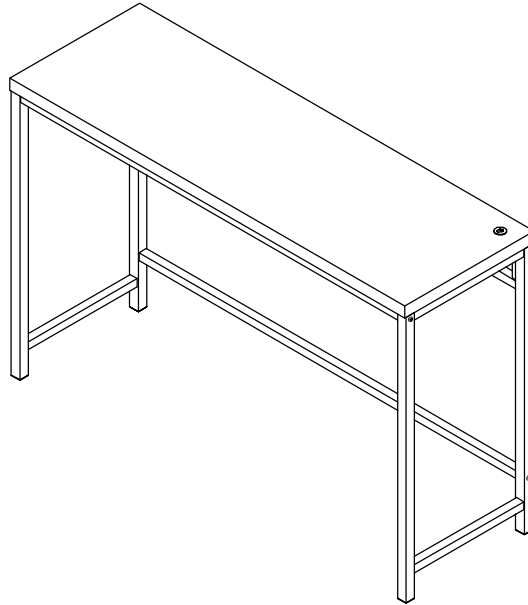

STEP 6

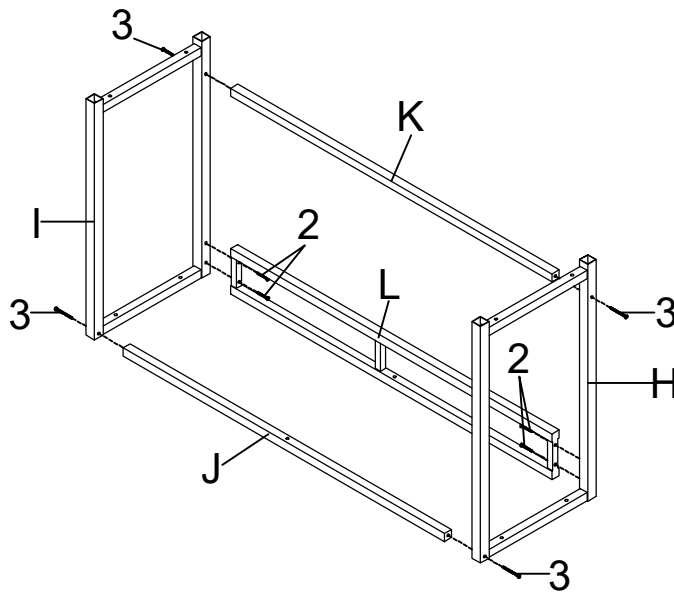

ITEM:182724

ASSEMBLY INSTRUCTIONS

STEP 7

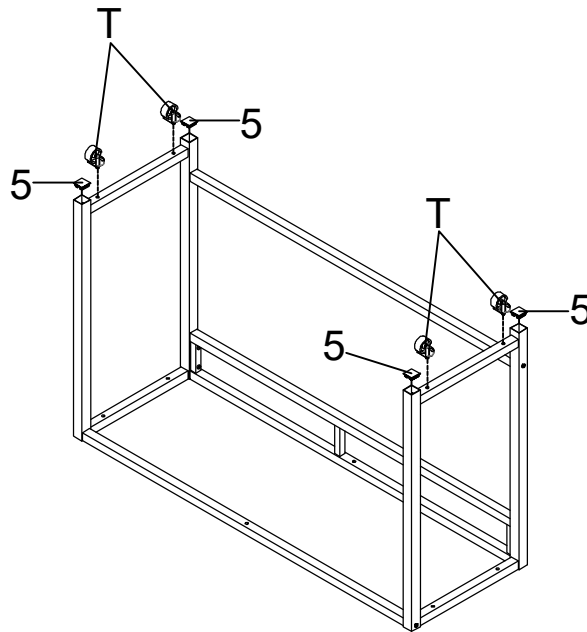

STEP 8

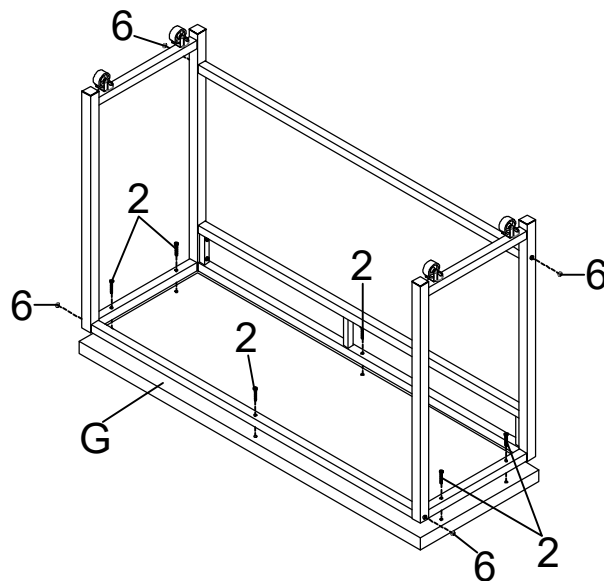

ITEM:182724
ASSEMBLY INSTRUCTIONS
STEP 9

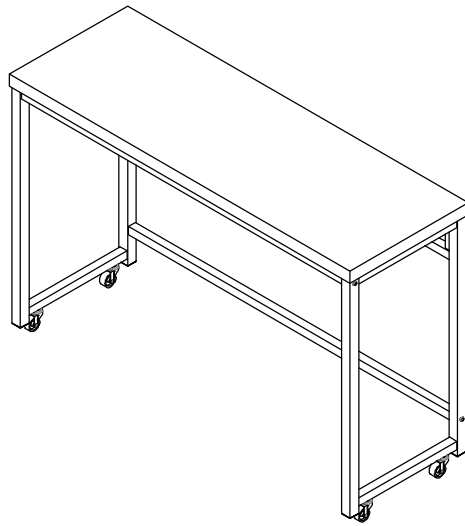

STEP 10

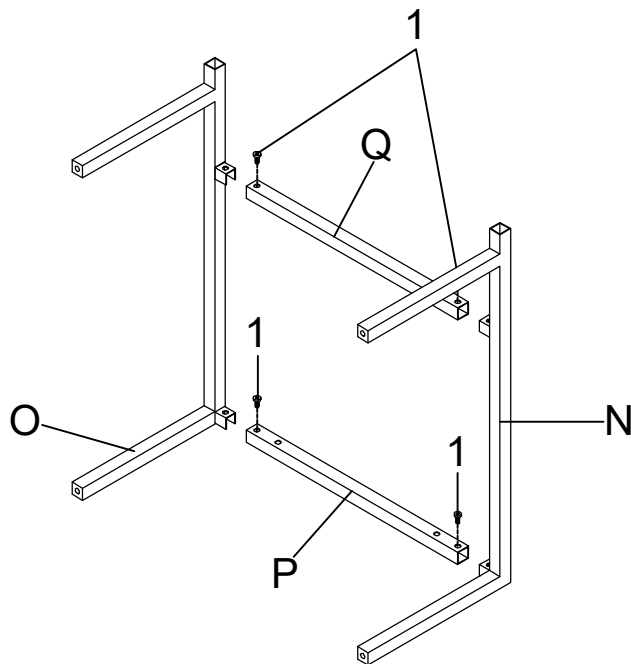

ITEM:182724
ASSEMBLY INSTRUCTIONS
STEP 11

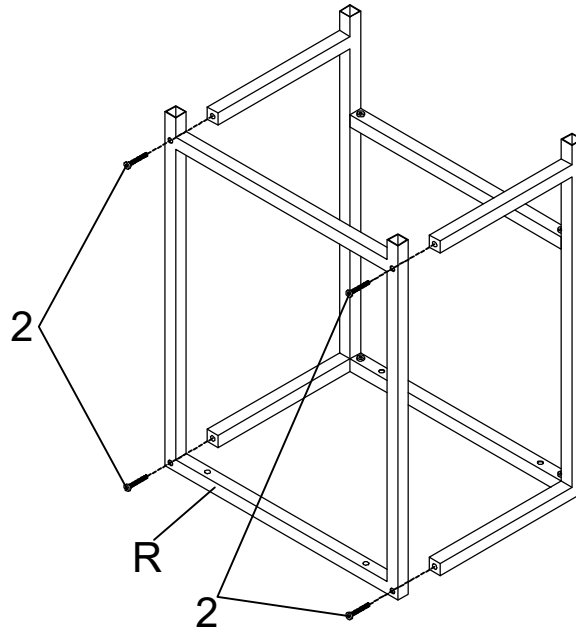

STEP 12

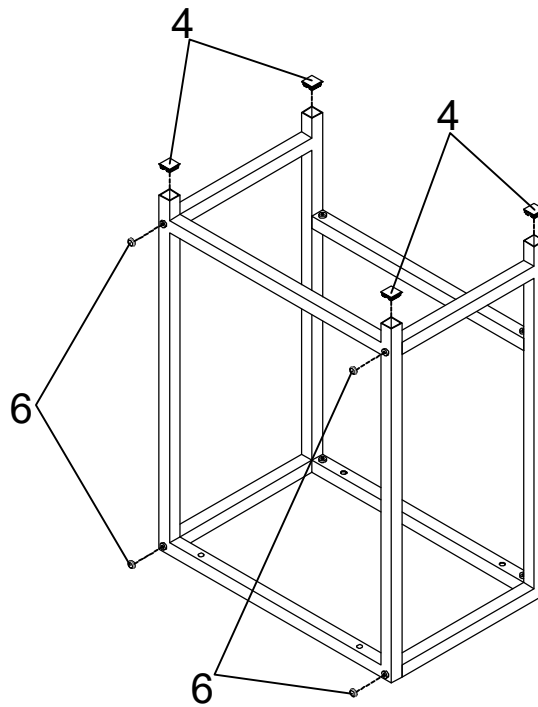

ITEM:182724
ASSEMBLY INSTRUCTIONS
STEP 13

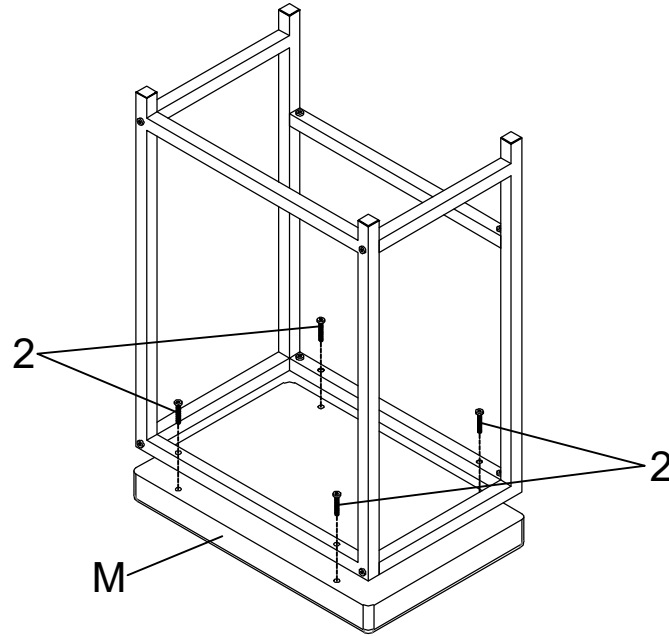

STEP 14

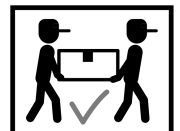
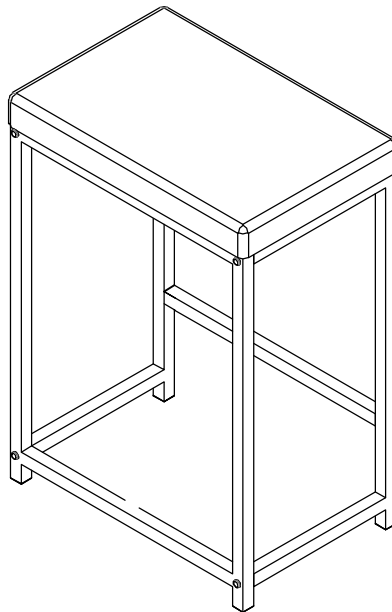

ITEM:182724 ASSEMBLY INSTRUCTIONS



Product Size : 1397 X 457 X 914 H (MM)
Product Size : 55" X 18" X 36"

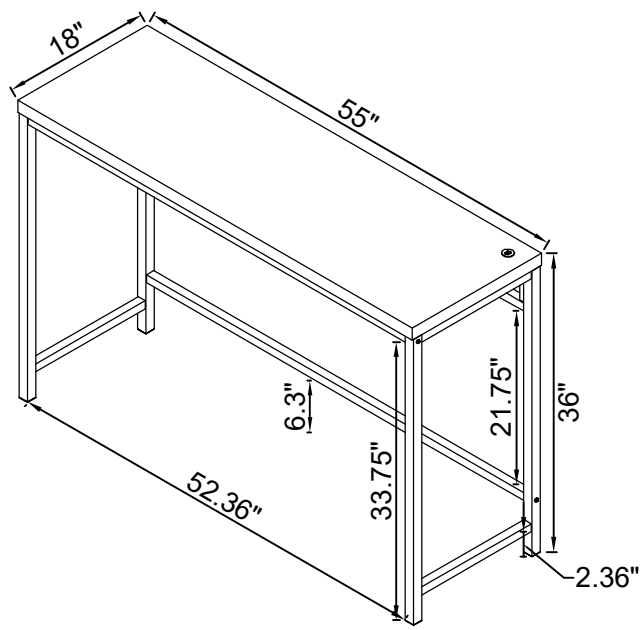

Product Size : 1207 X 419 X 819 H (MM)
Product Size : 47.5" X 16.5" X 32.25"

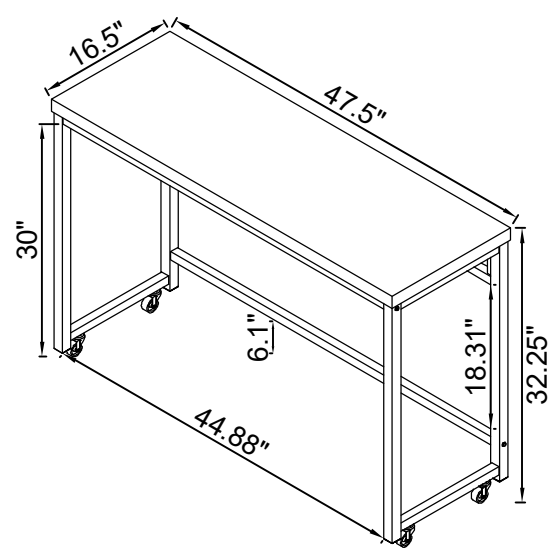

Note : Dimension tolerance $\pm 5\%$

ITEM:182724 ASSEMBLY INSTRUCTIONS



Product Size : 457 X 305 X 635 H (MM)

Product Size : 18" X 12" X 25"

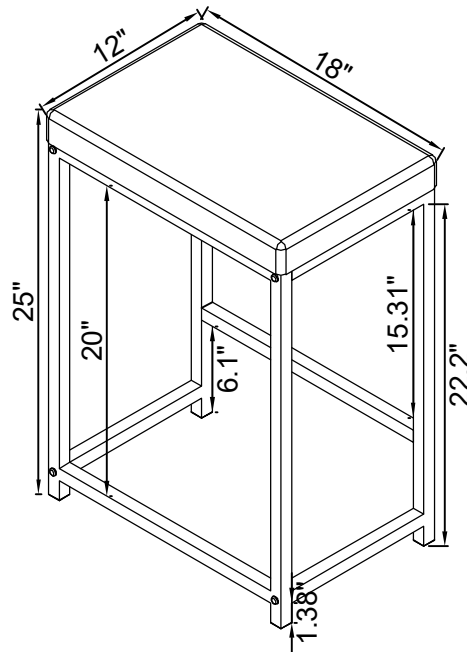

Note : Dimension tolerance $\pm 5\%$