

*ASSEMBLY INSTRUCTIONS*  
*COASTER FINE FURNITURE*



*Fine Furniture for every stage of life*

**182704**  
**4 PC COUNTER HT DINING SET**

REVISION 0 : 12/01/2023

PAGE 1 OF 16

COASTERFURNITURE.COM

ITEM:182704



# ASSEMBLY INSTRUCTIONS

## ASSEMBLY TIPS:

1. Remove hardware from box and sort by size.
2. Please check to see that all hardware and parts are present prior to start of assembly.
3. Please follow attached instructions in the same sequence as numbered to assure fast & easy assembly.



## WARNING!

1. Don't attempt to repair or modify parts that are broken or defective. Please contact the store immediately.
2. This product is for home use only and not intended for commercial establishments.

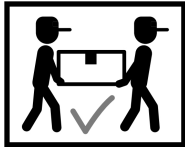

ASSEMBLY TIME 95 MINUTES

## PARTS IDENTIFICATION

A LARGE TOP PANEL

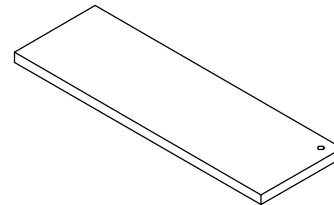

1PC

B LARGE LEFT PANEL

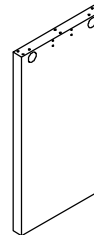

1PC

C LARGE RIGHT PANEL



1PC

D LARGE TOP CROSSBAR

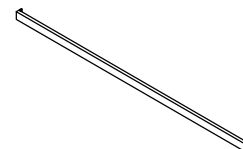

2PCS

E LARGE BOTTOM CROSSBAR

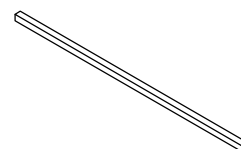

1PC

ITEM:182704

# ASSEMBLY INSTRUCTIONS

## PARTS IDENTIFICATION



F

SMALL TOP PANEL

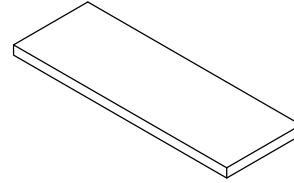

1PC

G

SMALL LEFT PANEL

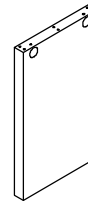

1PC

H

SMALL RIGHT PANEL

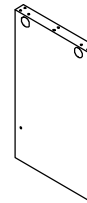

1PC

I

SMALL BOTTOM CROSSBAR

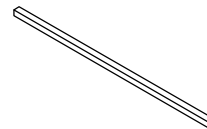

1PC

J

CUSHION SEAT

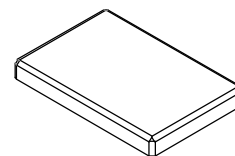

1PC

K

STOOL LEFT FRAME



1PC

ITEM:182704

# ASSEMBLY INSTRUCTIONS

## PARTS IDENTIFICATION



L

STOOL RIGHT FRAME

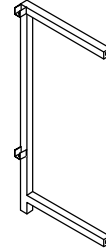

1PC

M

STOOL TOP CROSSBAR

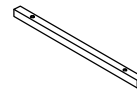

1PC

N

STOOL BOTTOM CROSSBAR

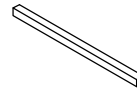

1PC

O

STOOL FRONT FRAME

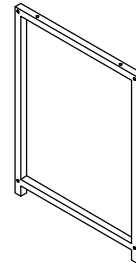

1PC

P

USB

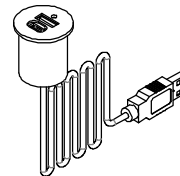

1PC

Q

WHEEL

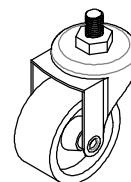

4PCS













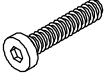

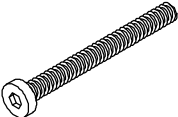
ITEM:182704



# ASSEMBLY INSTRUCTIONS

Z

## HARDWARE IDENTIFICATION

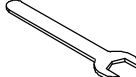
1	SHORT BOLT (1/4" x 12mm BLK)		12PCS	9	FLOOR PROTECTOR		4PCS
2	MEDIUM BOLT (1/4" x 35mm BLK)		8PCS	10	SMALL CAP (20 x 20mm BLK)		4PCS
3	LONG BOLT (1/4" x 56mm BLK)		4PCS	11	COVER		4PCS
4	WOOD DOWEL (8 x 50mm)		24PCS	12	GLUE		1PC
5	HANGER BOLT (5/16" x 50mm)		8PCS	13	LARGE STICKER		8PCS
6	HALF ROUND WASHER		8PCS	14	SMALL STICKER		4PCS
7	NUT (5/16")		8PCS	15	ALLEN WRENCH (4mm)		1PC
8	WASHER (1/4" x 16mm)		4PCS	16	WRENCH		1PC

NOTE:QUANTITIES SHOWN ARE FOR ONE LARGE TABLE, ONE SMALL TABLE AND ONE STOOL

ITEM:182704



# ASSEMBLY INSTRUCTIONS

**STEP 1** Do not tighten until each step is completed or instructed.

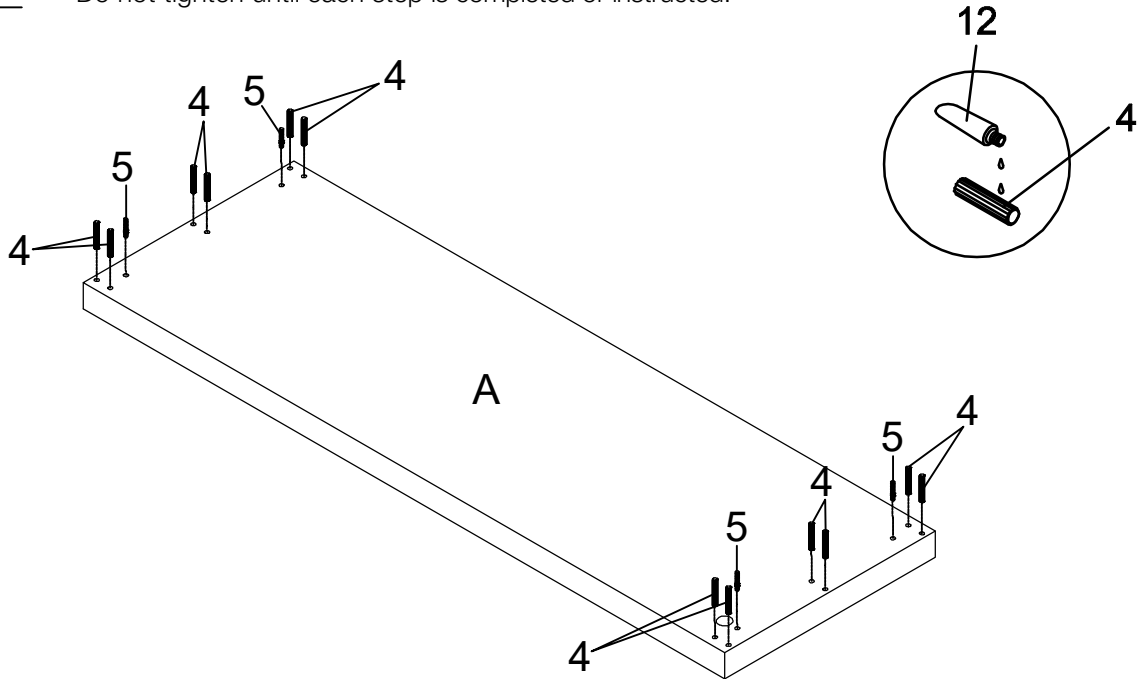

## STEP 2

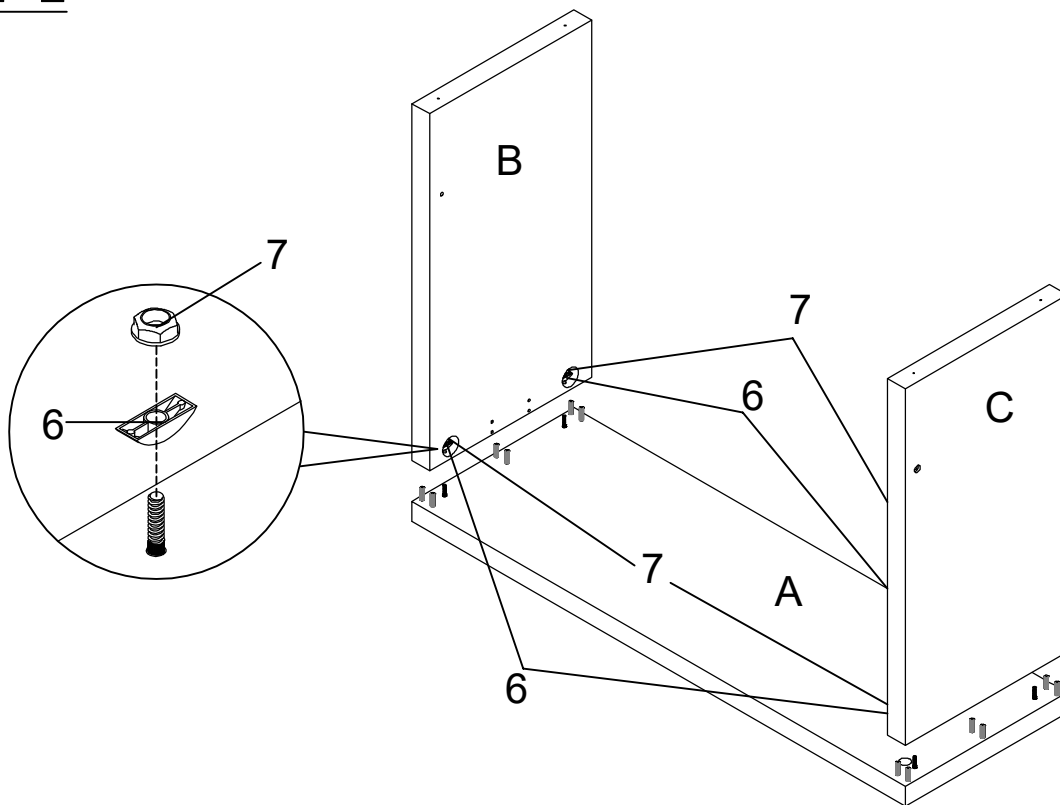

ITEM:182704  
ASSEMBLY INSTRUCTIONS  
STEP 3

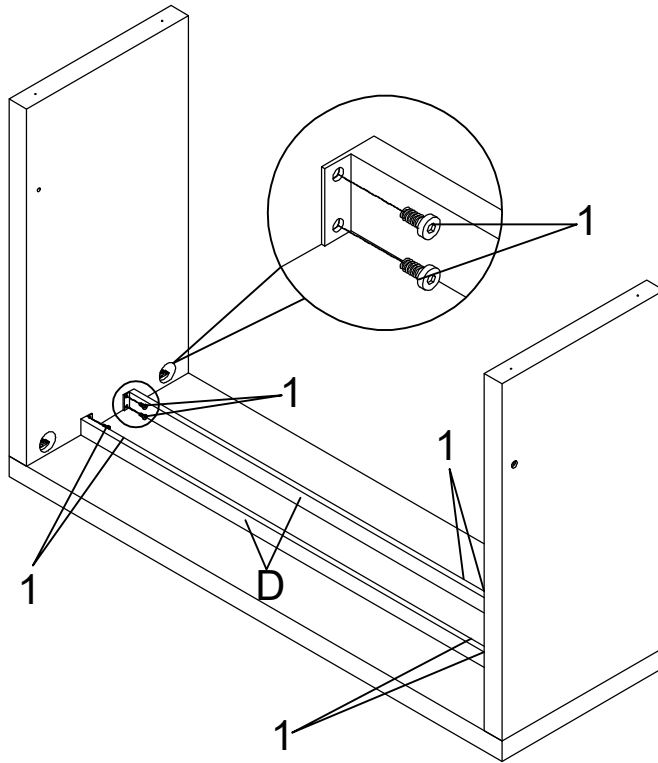

STEP 4

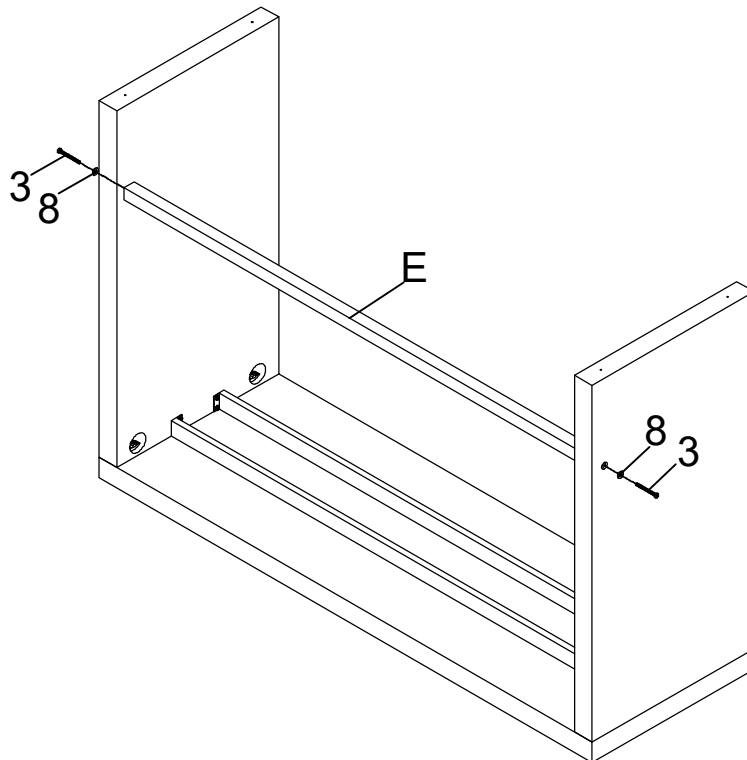

ITEM:182704

# ASSEMBLY INSTRUCTIONS

## STEP 5

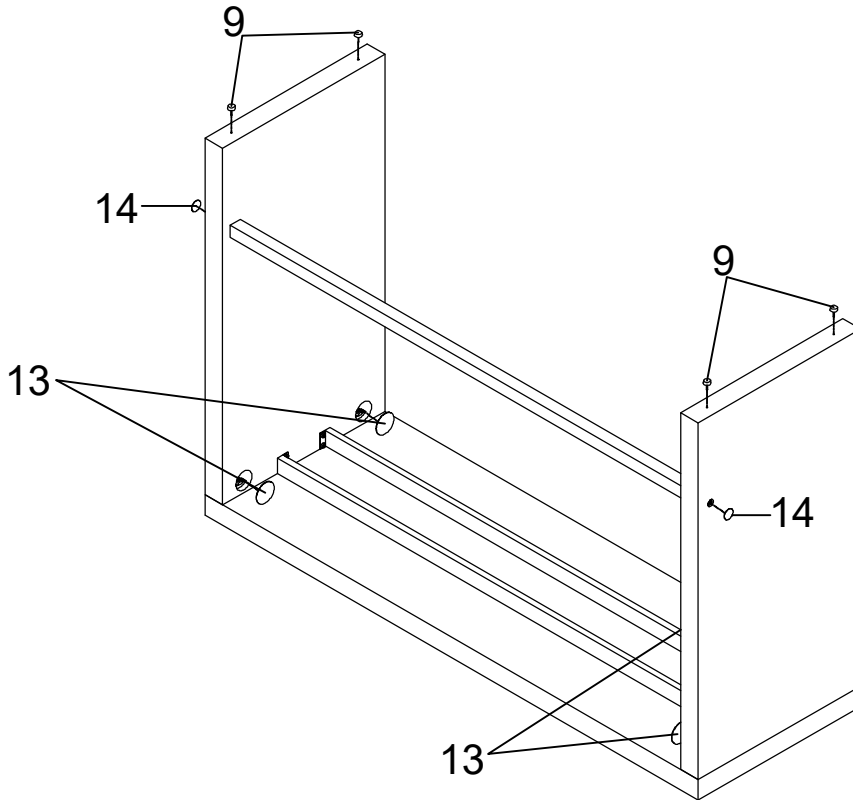

## STEP 6

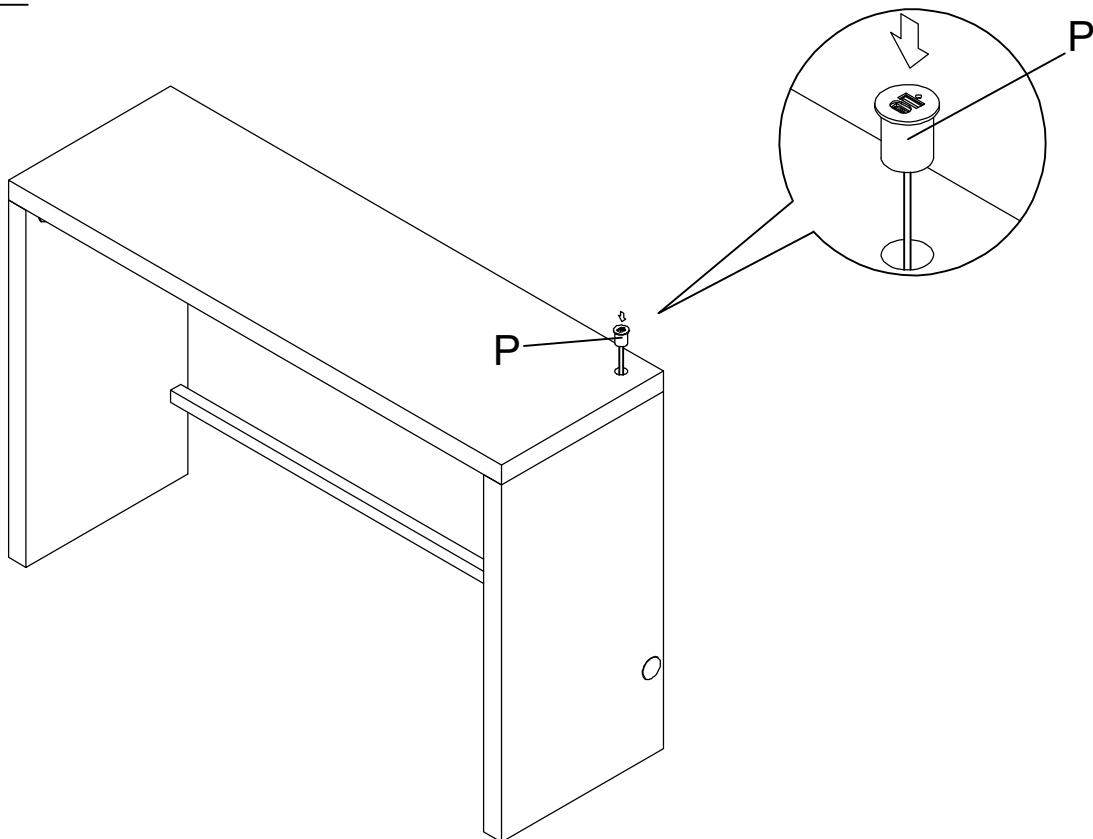



ITEM:182704

# ASSEMBLY INSTRUCTIONS

## STEP 7

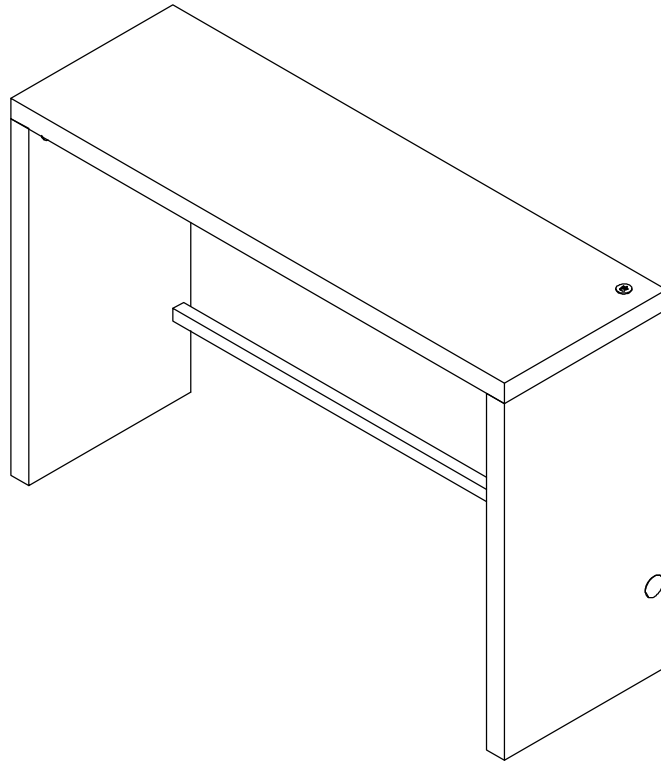

## STEP 8

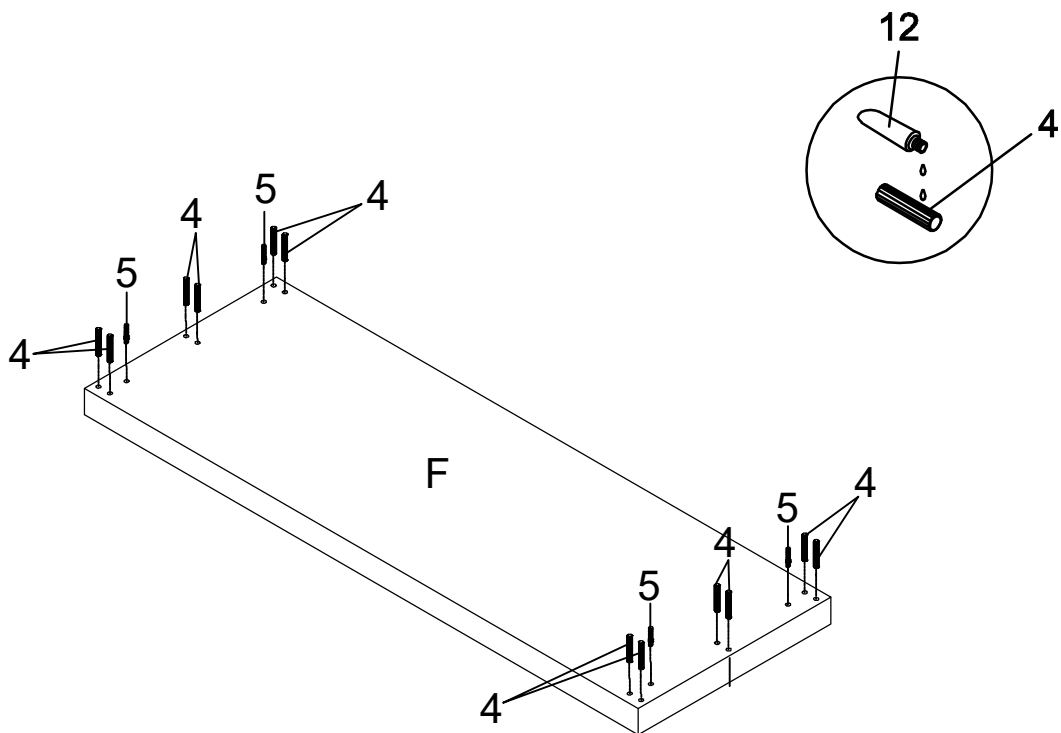

ITEM:182704  
ASSEMBLY INSTRUCTIONS  
STEP 9

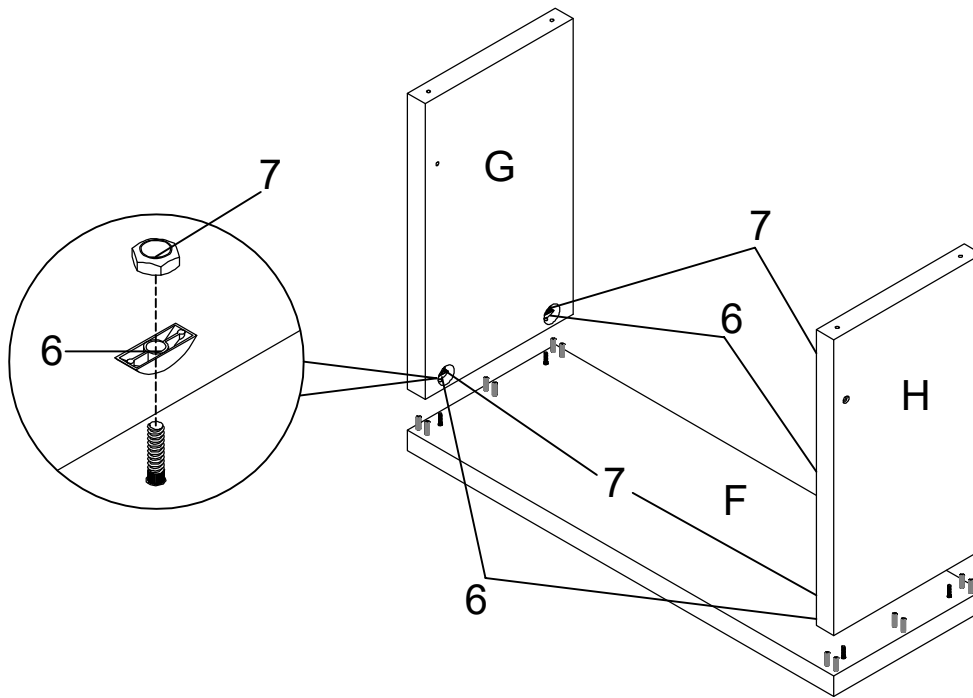

STEP 10

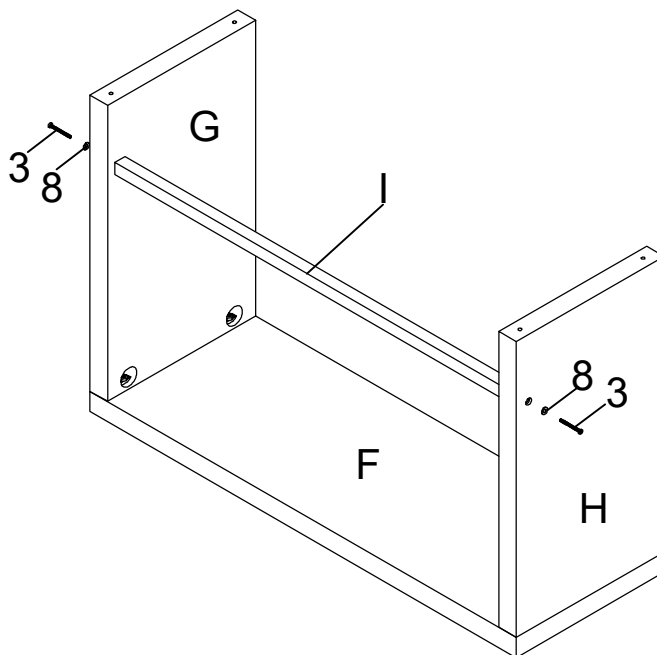

ITEM:182704  
ASSEMBLY INSTRUCTIONS  
STEP 11

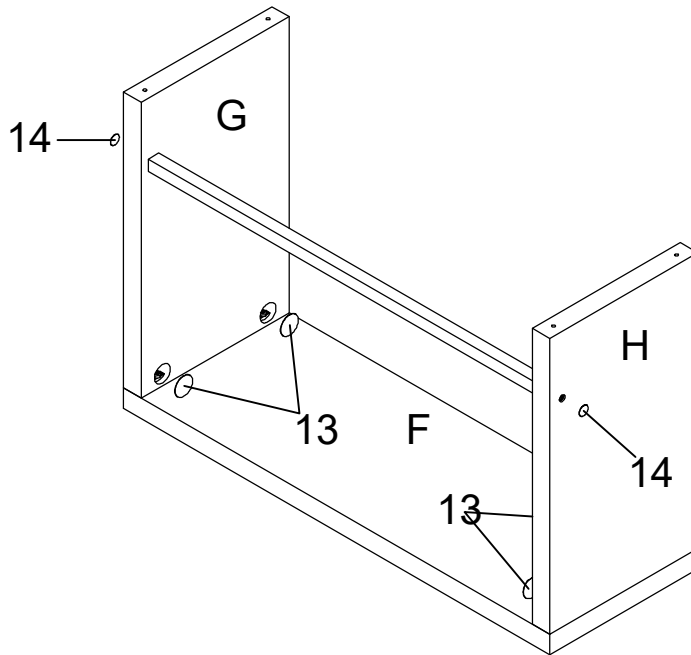

STEP 12

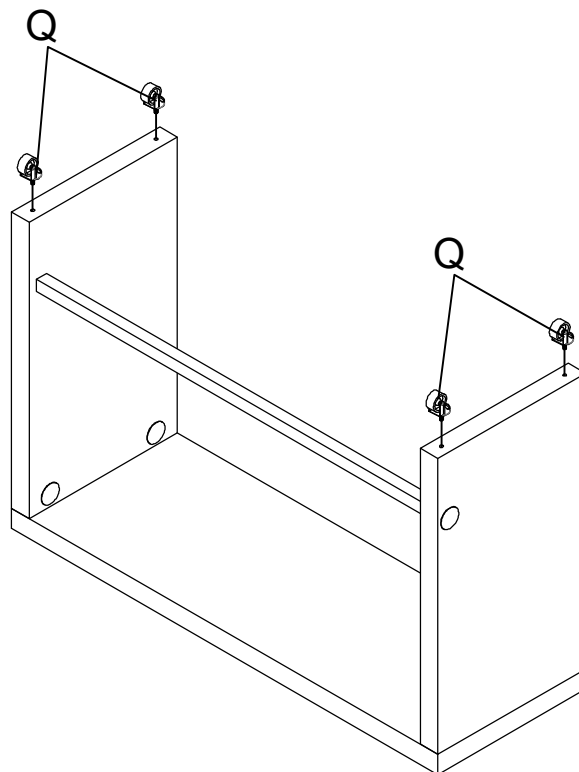

ITEM:182704  
ASSEMBLY INSTRUCTIONS  
STEP 13

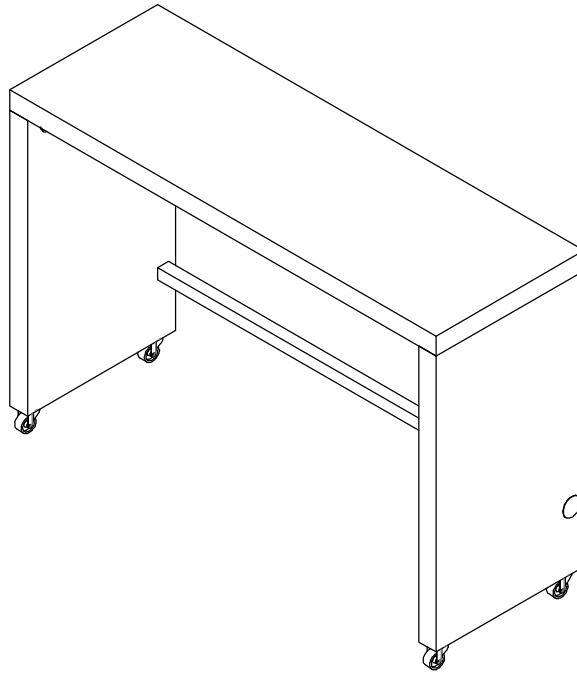

STEP 14

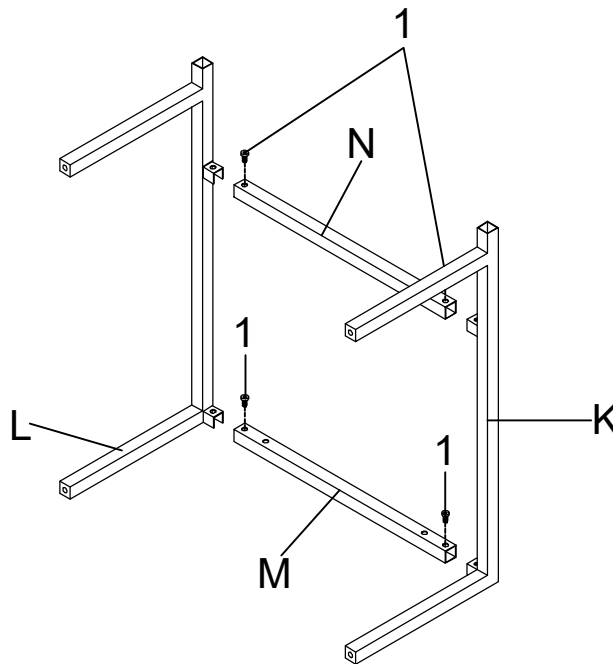

ITEM:182704  
ASSEMBLY INSTRUCTIONS  
STEP 15

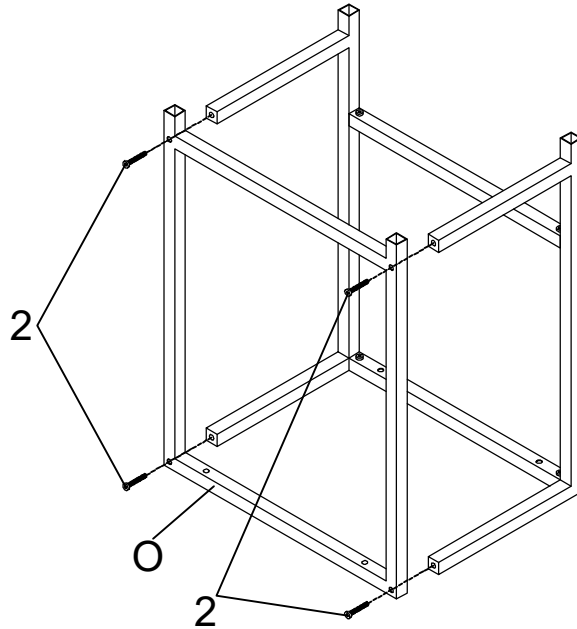

STEP 16

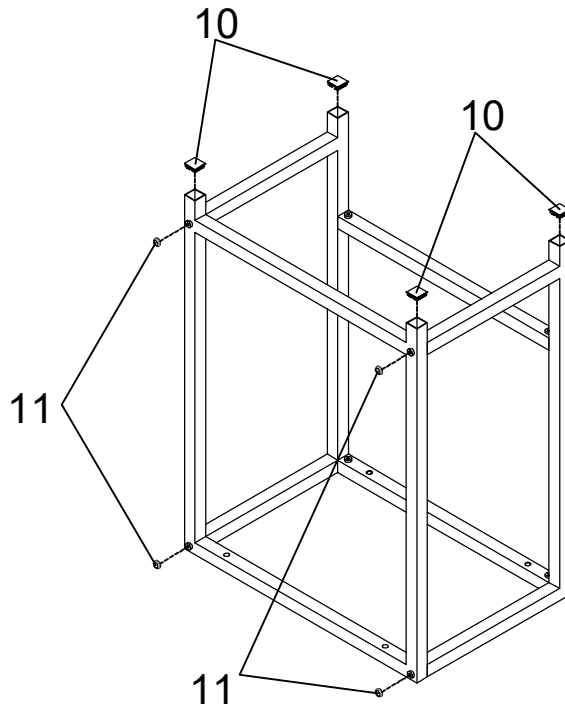

ITEM:182704  
ASSEMBLY INSTRUCTIONS  
STEP 17

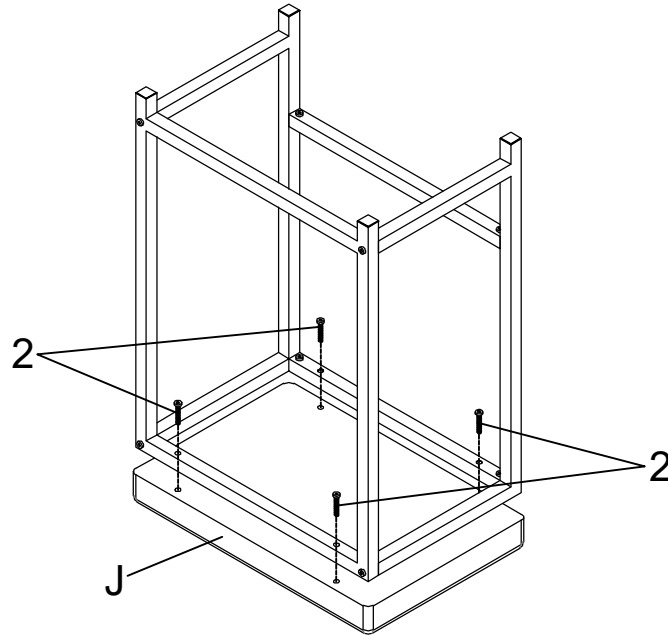

STEP 18

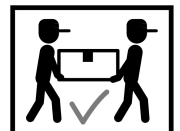
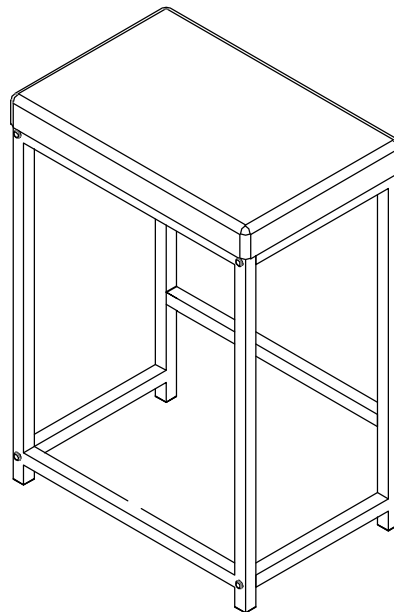

# ITEM:182704 ASSEMBLY INSTRUCTIONS



**Product Size : 1397 X 457 X 933 H (MM)**  
**Product Size : 55" X 18" X 36.75"**

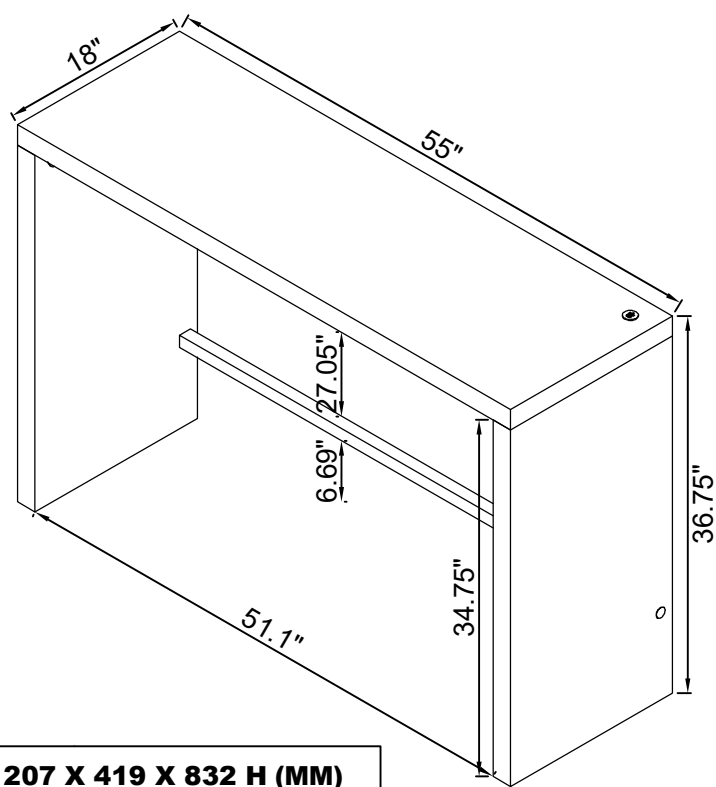

**Product Size : 1207 X 419 X 832 H (MM)**  
**Product Size : 47.5" X 16.5" X 32.75"**

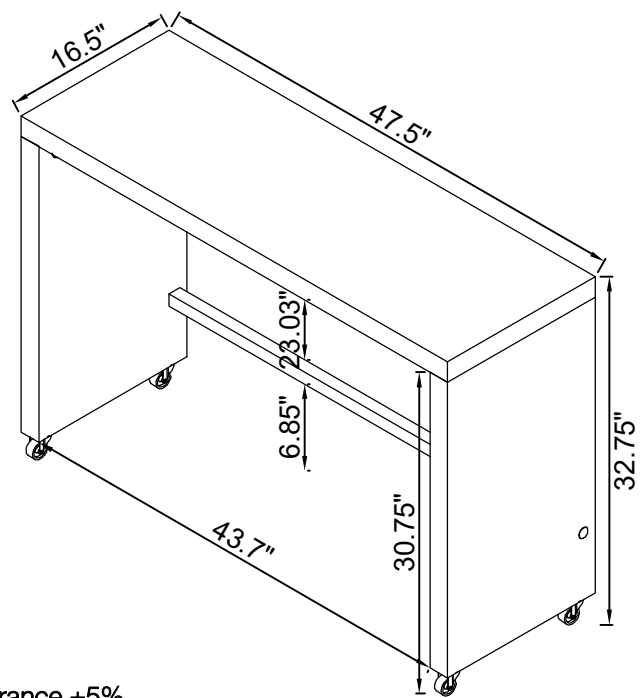

Note : Dimension tolerance  $\pm 5\%$

# ITEM:182704 ASSEMBLY INSTRUCTIONS



<b>Product Size : 457 X 305 X 635 H (MM)</b>
<b>Product Size : 18" X 12" X 25"</b>

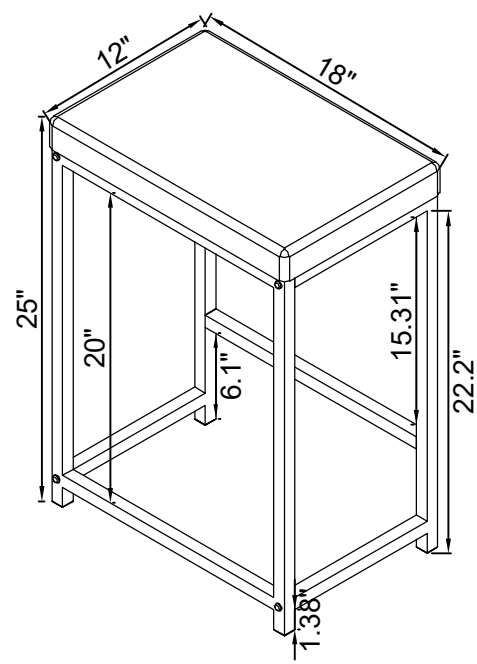

Note : Dimension tolerance  $\pm 5\%$