

**ASSEMBLY INSTRUCTIONS**  
**COASTER FINE FURNITURE**



*Fine Furniture for every stage of life*

**122246(B1&B2)**  
***Kitchen Island***

# ITEM: 122246(B1&B2)



## ASSEMBLY INSTRUCTIONS

### ASSEMBLY TIPS:

1. Remove hardware from box and sort by size.
2. Please check to see that all hardware and parts are present prior to start of assembly.
3. Please follow attached instructions in the same sequence as numbered to assure fast & easy assembly.



### WARNING!

1. Don't attempt to repair or modify parts that are broken or defective. Please contact the store immediately.
2. This product is for home use only and not intended for commercial establishments.







ASSEMBLY TIME



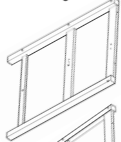
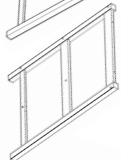

60 MINUTES

## PARTS IDENTIFICATION

### B1 (BOX 1)

A	TOP		1PC
B	LEFT LEG FRAME		1PC
C	RIGHT LEG FRAME		1PC
D	APRON		2PCS
E	SHELF PANEL		2PCS
F	SHELF SUPPORT		4PCS

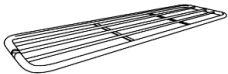
### B2 (BOX 2)

G	TOP FRAME		1PC
H	SIDE FRAME		2PCS
I	RACK		1PC
J	S HOOK		10PCS

### NOTE:

Phillips head screw driver is required in the assembly process; however, manufacturer does not provide this item.

# ITEM: 122246(B1&B2)



## ASSEMBLY INSTRUCTIONS

### ASSEMBLY TIPS:

1. Remove hardware from box and sort by size.
2. Please check to see that all hardware and parts are present prior to start of assembly.
3. Please follow attached instructions in the same sequence as numbered to assure fast & easy assembly.



### WARNING!

1. Don't attempt to repair or modify parts that are broken or defective. Please contact the store immediately.
2. This product is for home use only and not intended for commercial establishments.







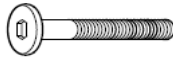

ASSEMBLY TIME

60 MINUTES

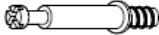
## HARDWARE IDENTIFICATION

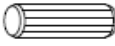
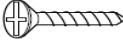
### Z-B1 (BOX 1) - HARDWARE PACK IS LOCATED IN 122246 (B1)

1	<b>SHORT BOLT</b> (M6 x 50mm - RBW)		4PCS
2	<b>LONG BOLT</b> (M6 x 80mm - RBW)		8PCS
3	<b>CAM NUT</b> (12mm - RBW)		16PCS
4	<b>CAM BOLT</b> (34mm - RBW)		16PCS
5	<b>BARREL NUT</b> (M6 x 13mm - RBW)		12PCS
6	<b>WOOD DOWEL</b> (M8 x 30mm)		8PCS
7	<b>FLAT HEAD SCREW</b> (M4 x 38mm - RBW)		10PCS
8	<b>WOOD PLUG</b> (14.5 x 9mm)		12PCS
9	<b>ALLEN WRENCH</b> (M4 x 60mm - BLK)		1PC

### Z-B2 (BOX 2) - HARDWARE PACK IS LOCATED IN 122246 (B2)

10	<b>PAN HEAD SCREW</b> (#8 x 5/8" - RBW)		8PCS
----	--------------------------------------------	--------------------------------------------------------------------------------------	------

### NOTE:

Phillips head screw driver is required in the assembly process; however, manufacturer does not provide this item.

# ITEM: 122246(B1&B2)

## ASSEMBLY INSTRUCTIONS



### STEP 1

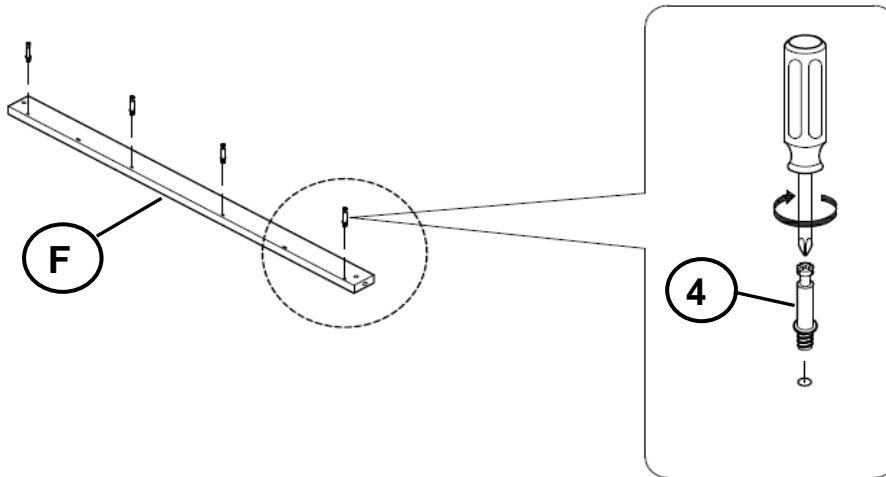

### STEP 2

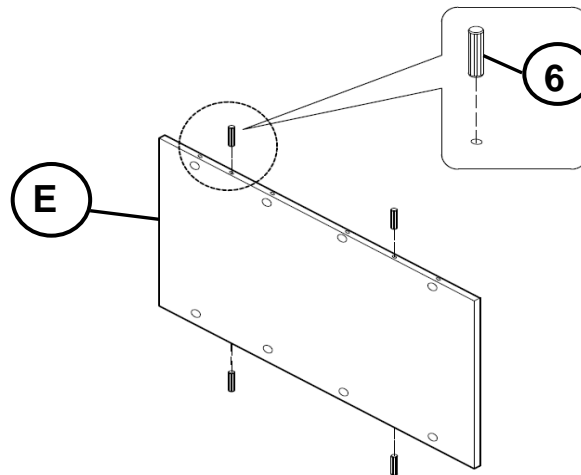

### STEP 3

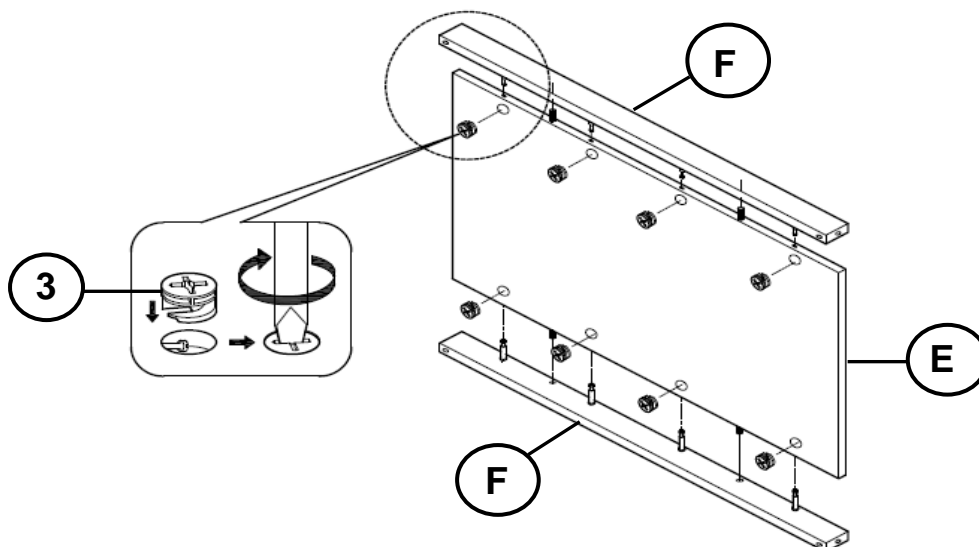

# ITEM: 122246(B1&B2)

## ASSEMBLY INSTRUCTIONS



### STEP 4

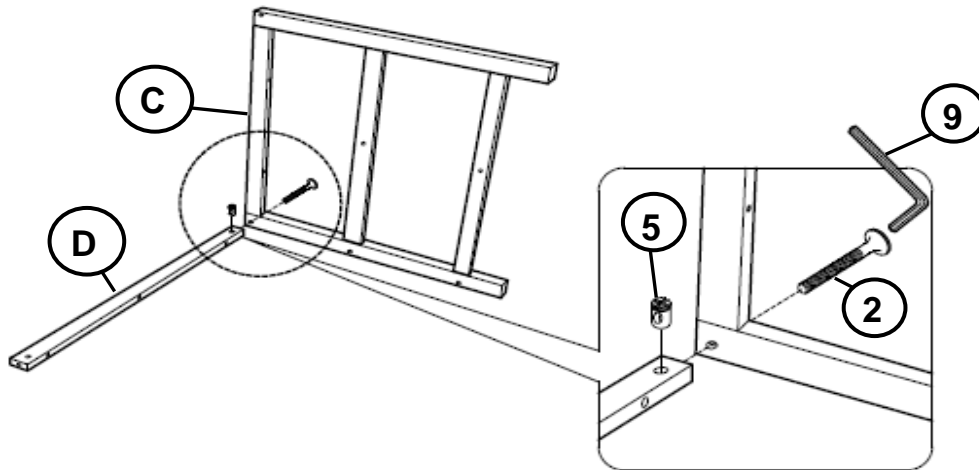

### STEP 5

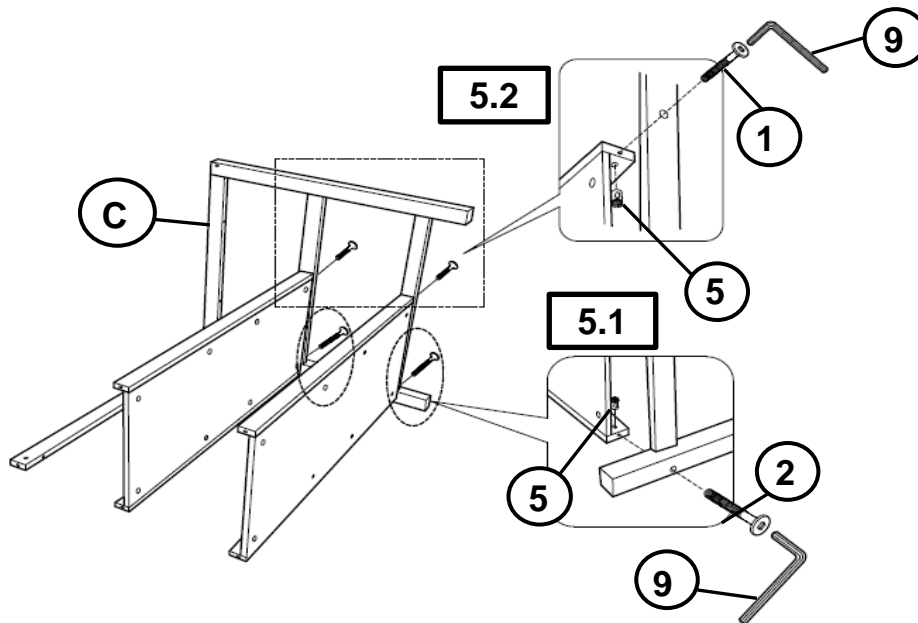

### STEP 6

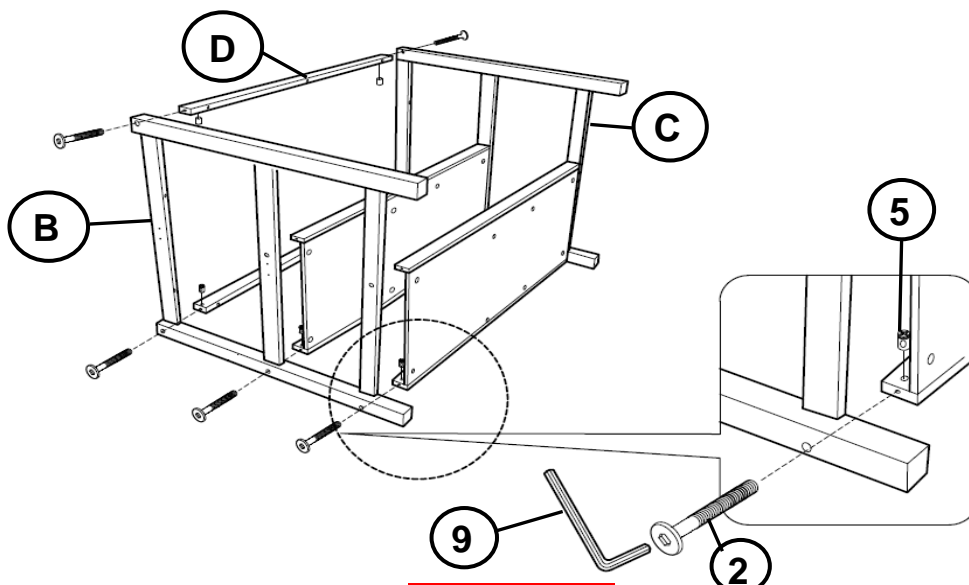

# ITEM: 122246(B1&B2)

## ASSEMBLY INSTRUCTIONS



### STEP 7

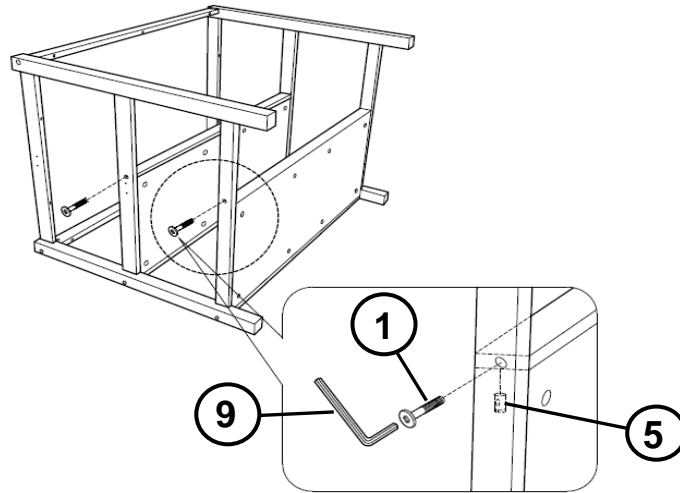

### STEP 8

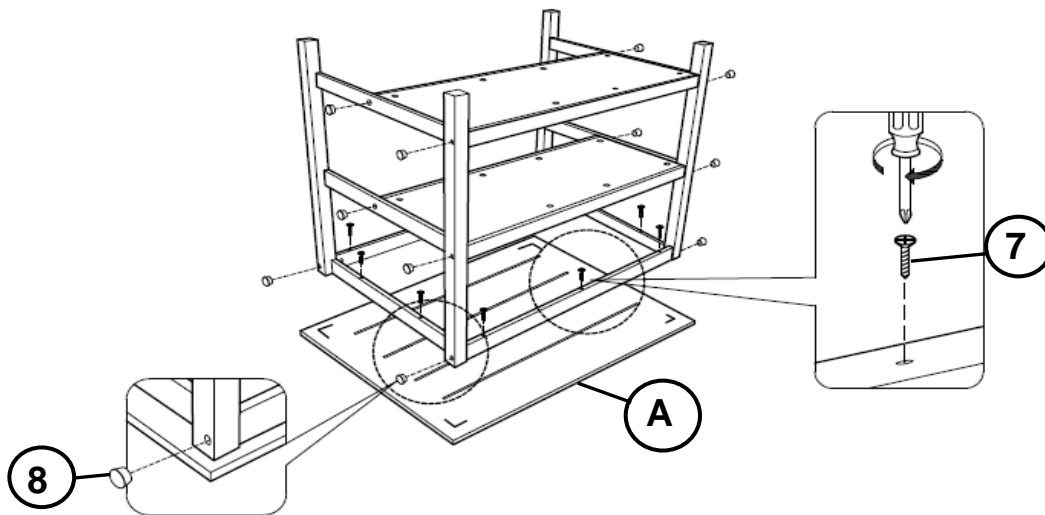

### STEP 9

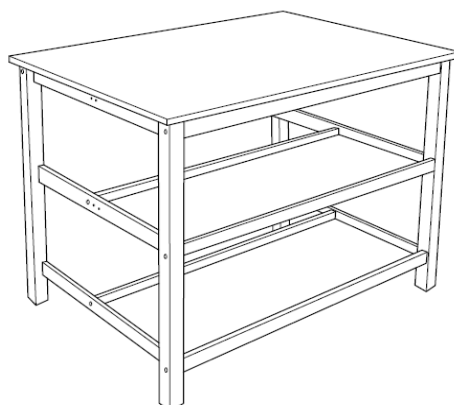

# ITEM: 122246(B1&B2)

## ASSEMBLY INSTRUCTIONS



### STEP 10

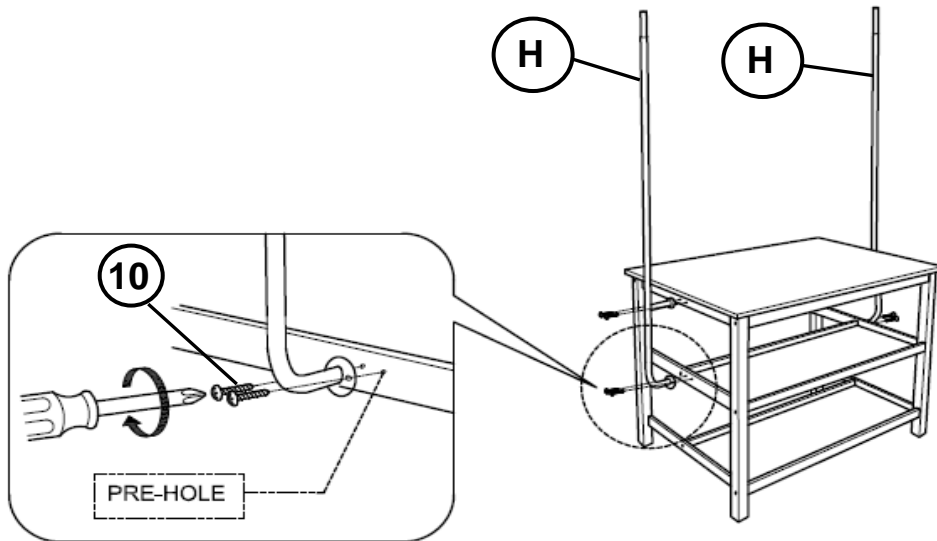

### STEP 11

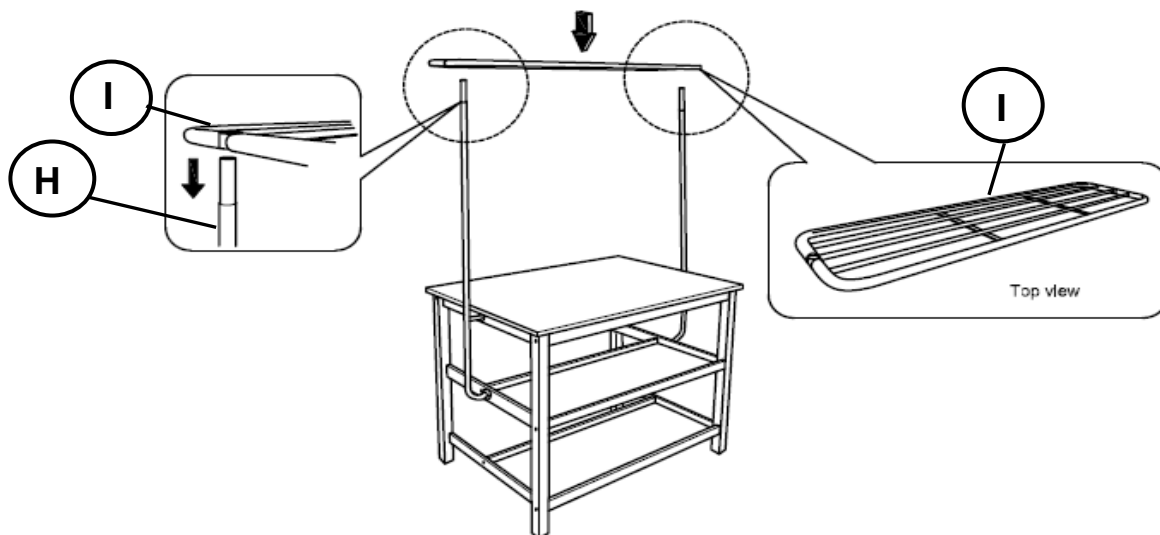

### STEP 12

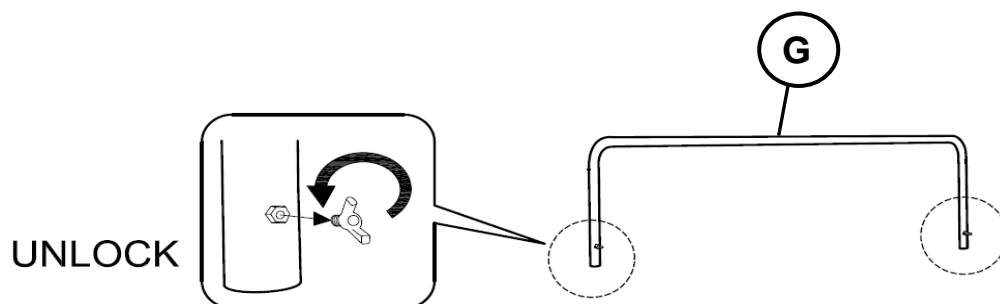

# ITEM: 122246(B1&B2)

## ASSEMBLY INSTRUCTIONS

### STEP 13

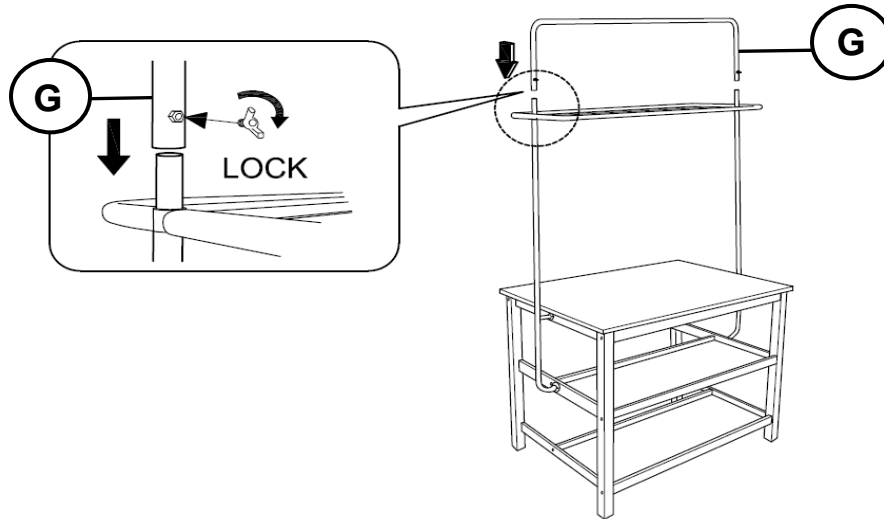

### STEP 14

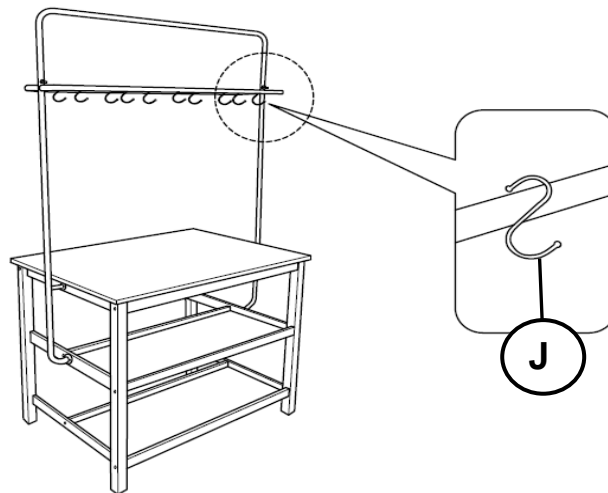

### STEP 15 **COMPLETE**

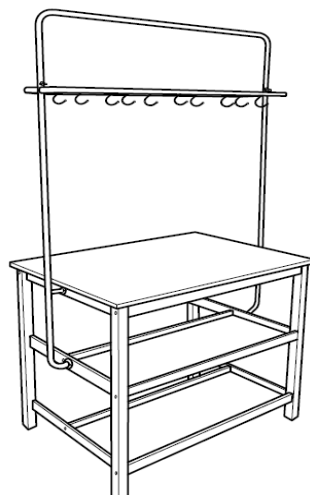



ITEM: 122246(B1&B2)

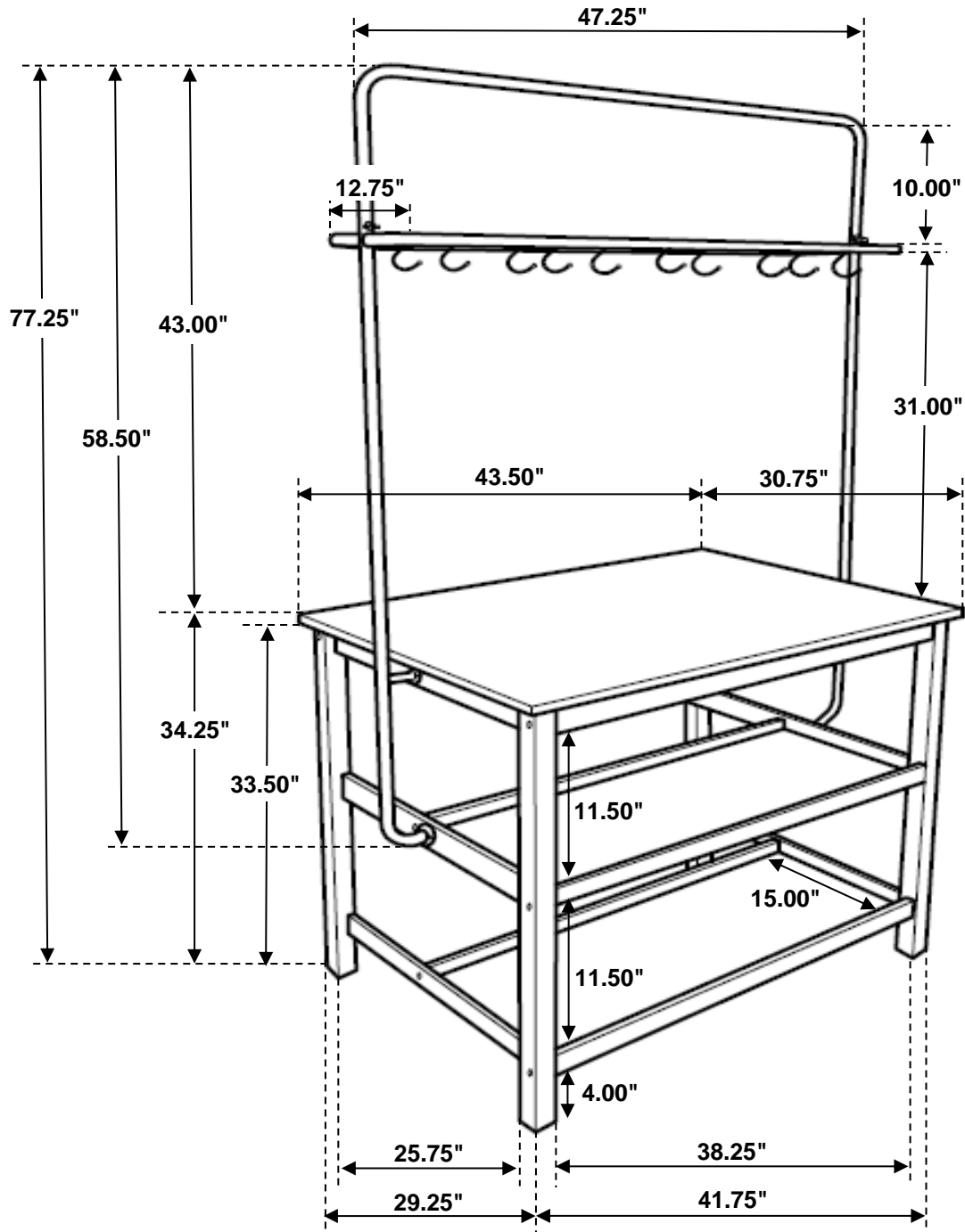

Note : Dimension tolerance  $\pm 5\%$