

Assembly Instruction

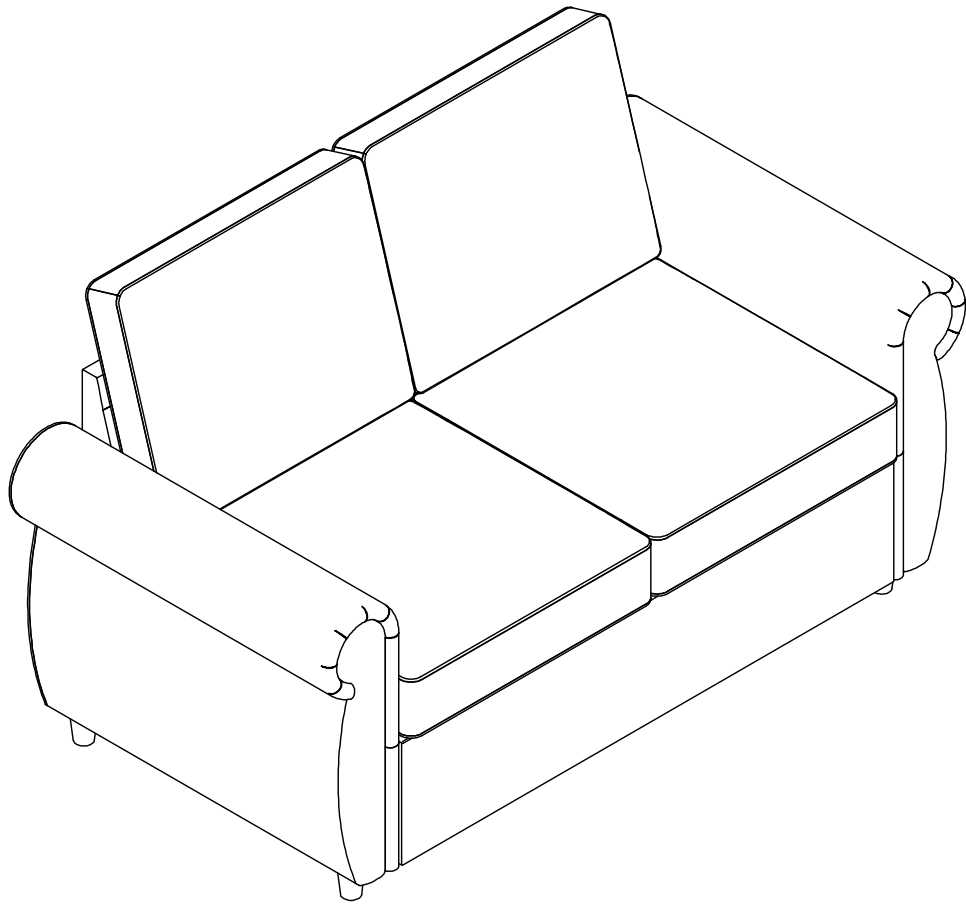

PARTS

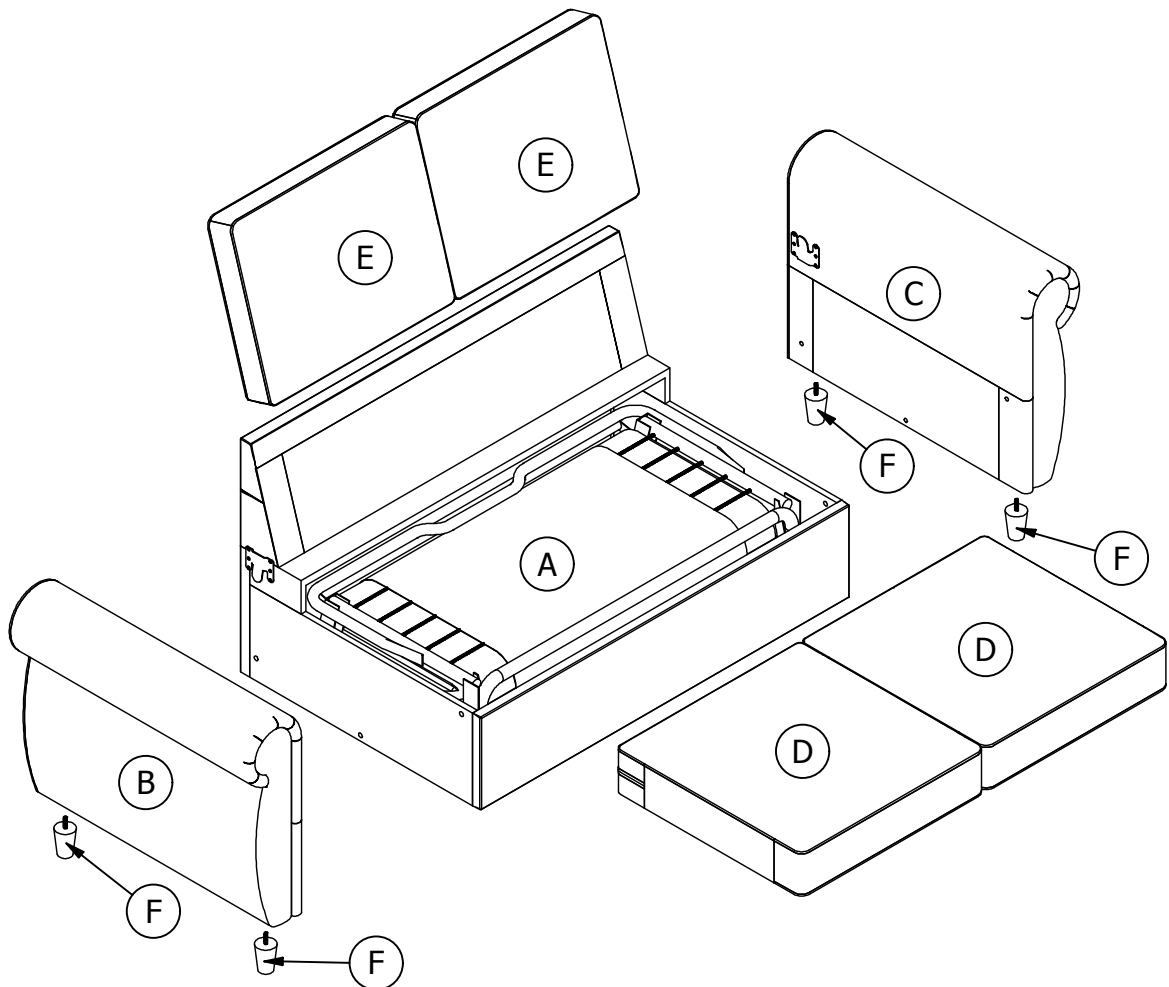

PARTS LIST

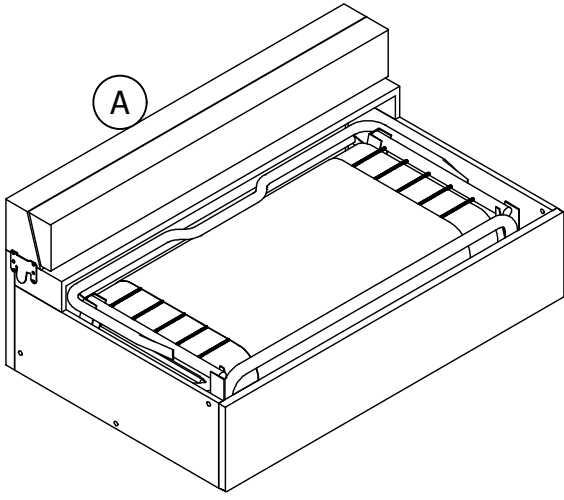

Seat X 1 PC

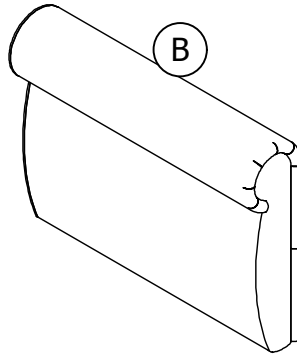

Arm X 1 PC

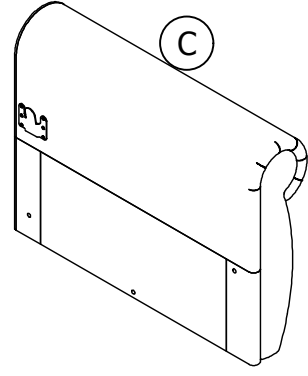

Arm X 1 PC

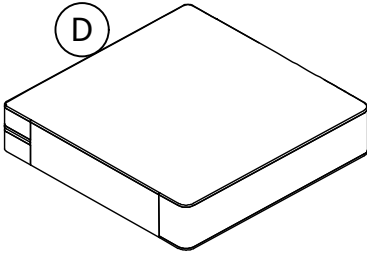

Seat Cushion X 2 PCS

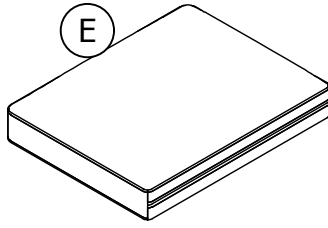

Back Cushion X 2 PCS

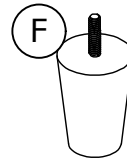

Leg X 4 PCS

HARDWARE

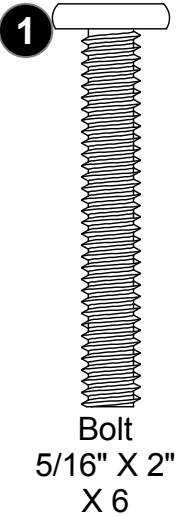

Bolt
5/16" X 2"
X 6

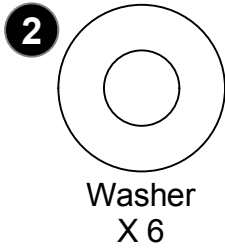

Washer
X 6



Spring Washer
X 6

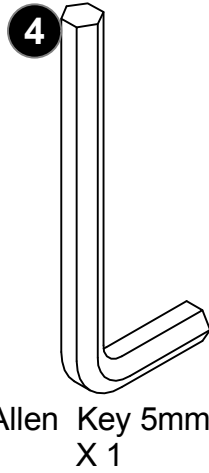

Allen Key 5mm
X 1

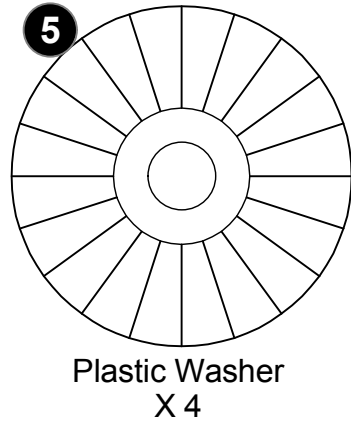

Plastic Washer
X 4

Step 1: The folding bed assembly has been secured with Tie-wraps for transportation purposes. DO NOT remove the tie-wraps on the front of bars of the assembly until you have finished Step 5 of the assembly process.

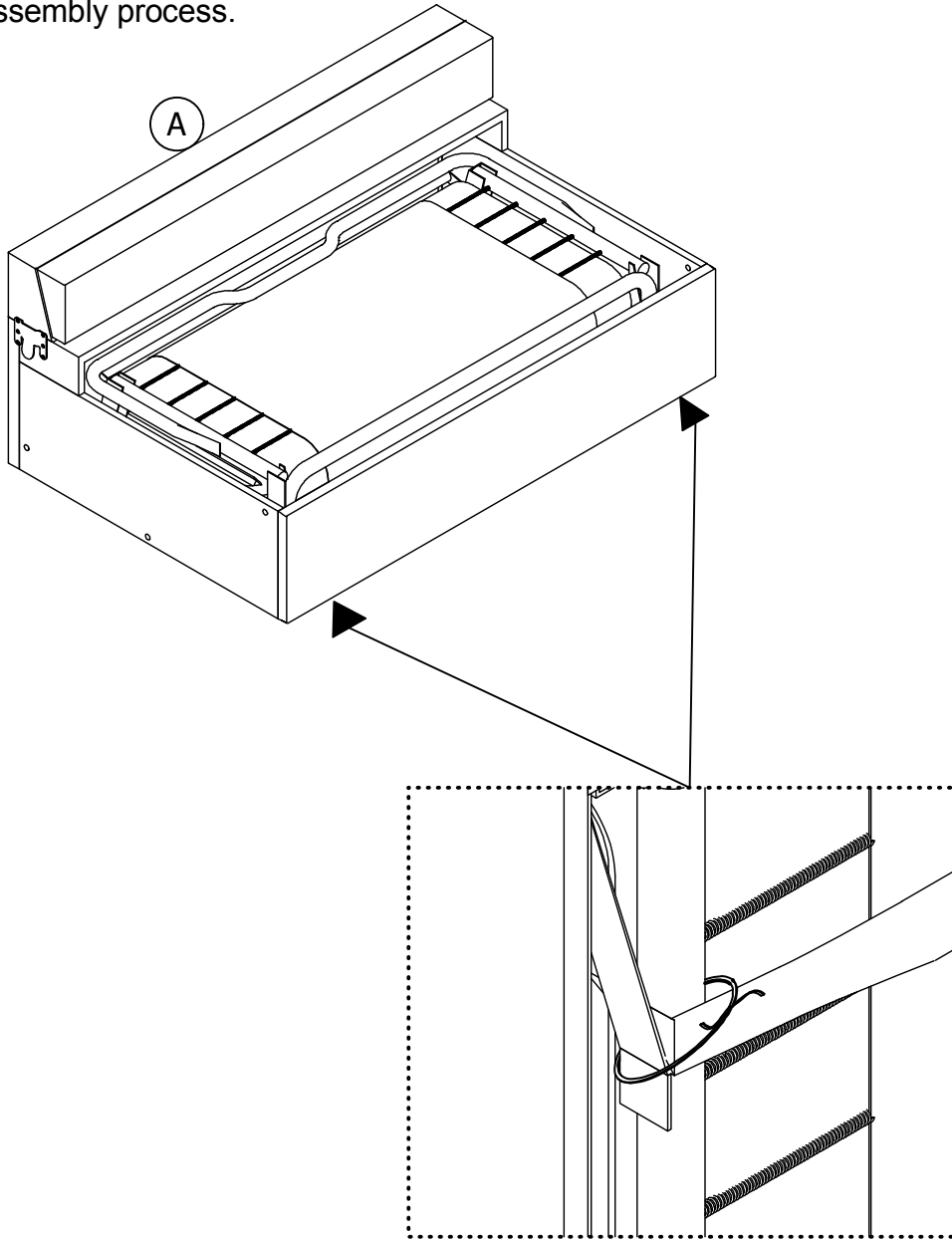

Step 2: Unfold the backrest, as show.

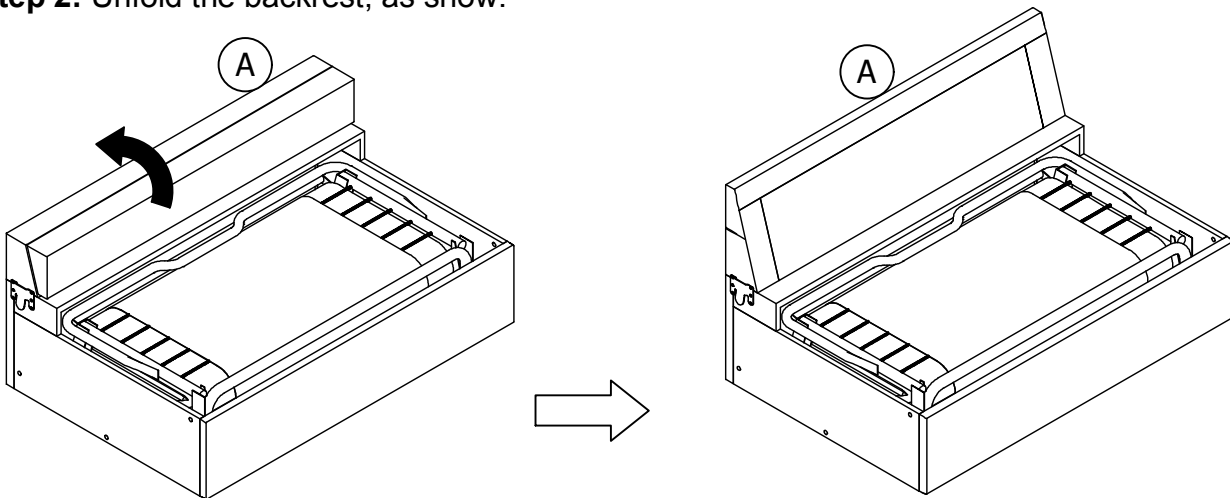

Step 3: Lay A on its back. Insert B & C into A.

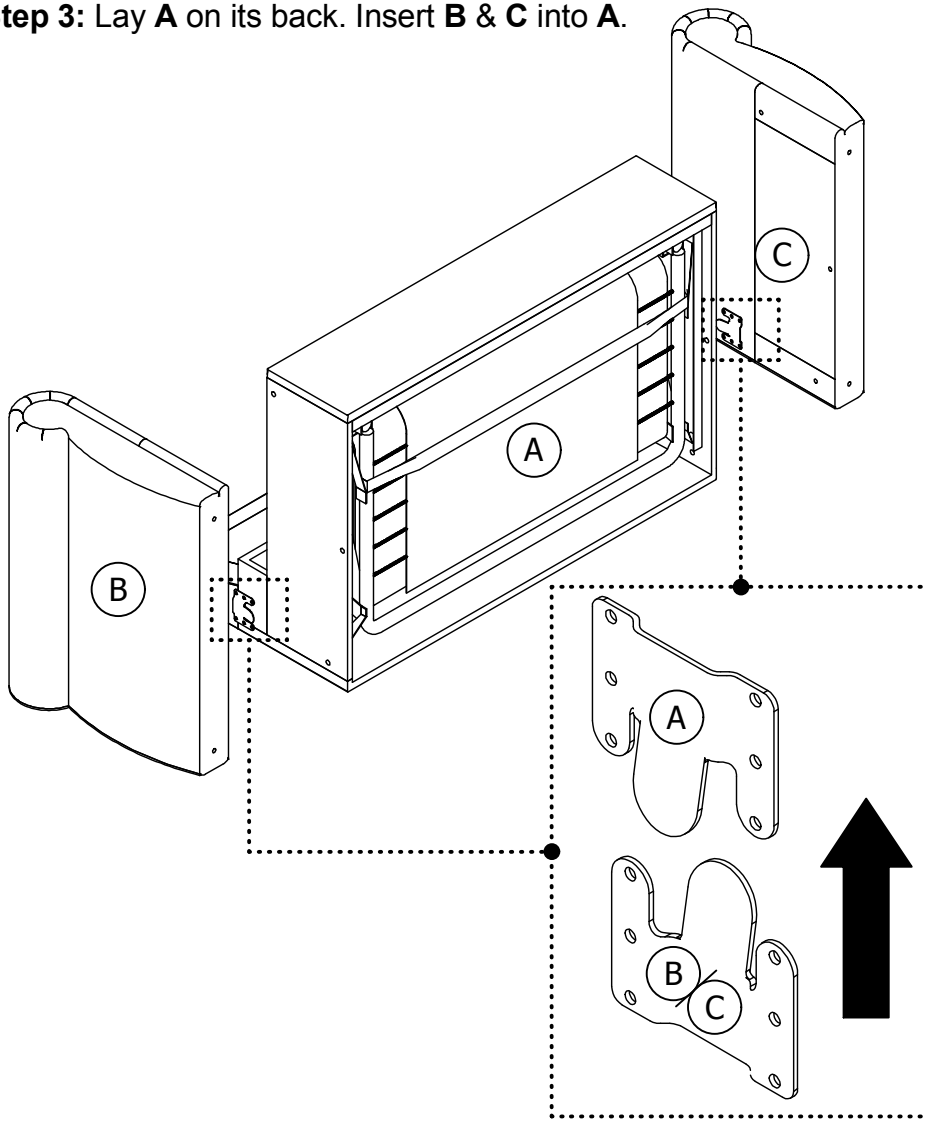

Step 4: Attach B & C to A with 1, 2, 3.

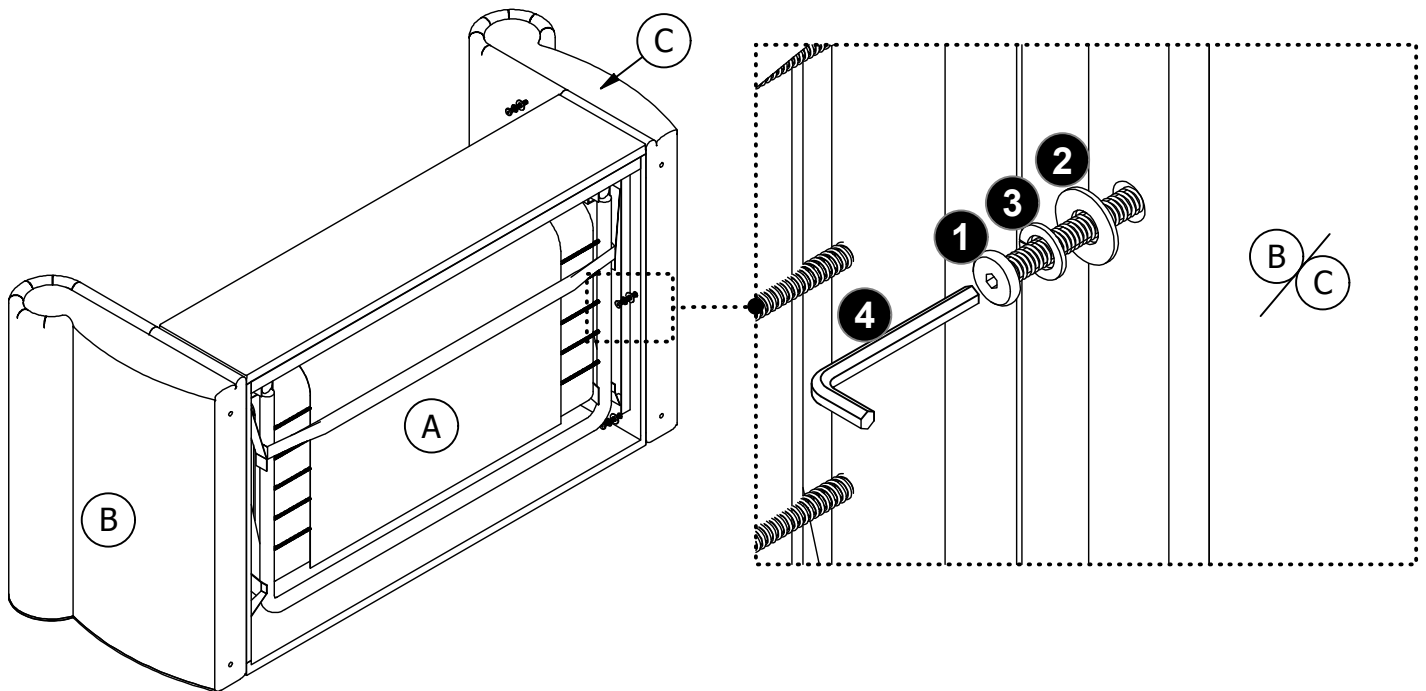

Step 5: Manually screw F x 4 to B & C with **5**.

! Please remove the protective cap on the tip of thread before assembling.

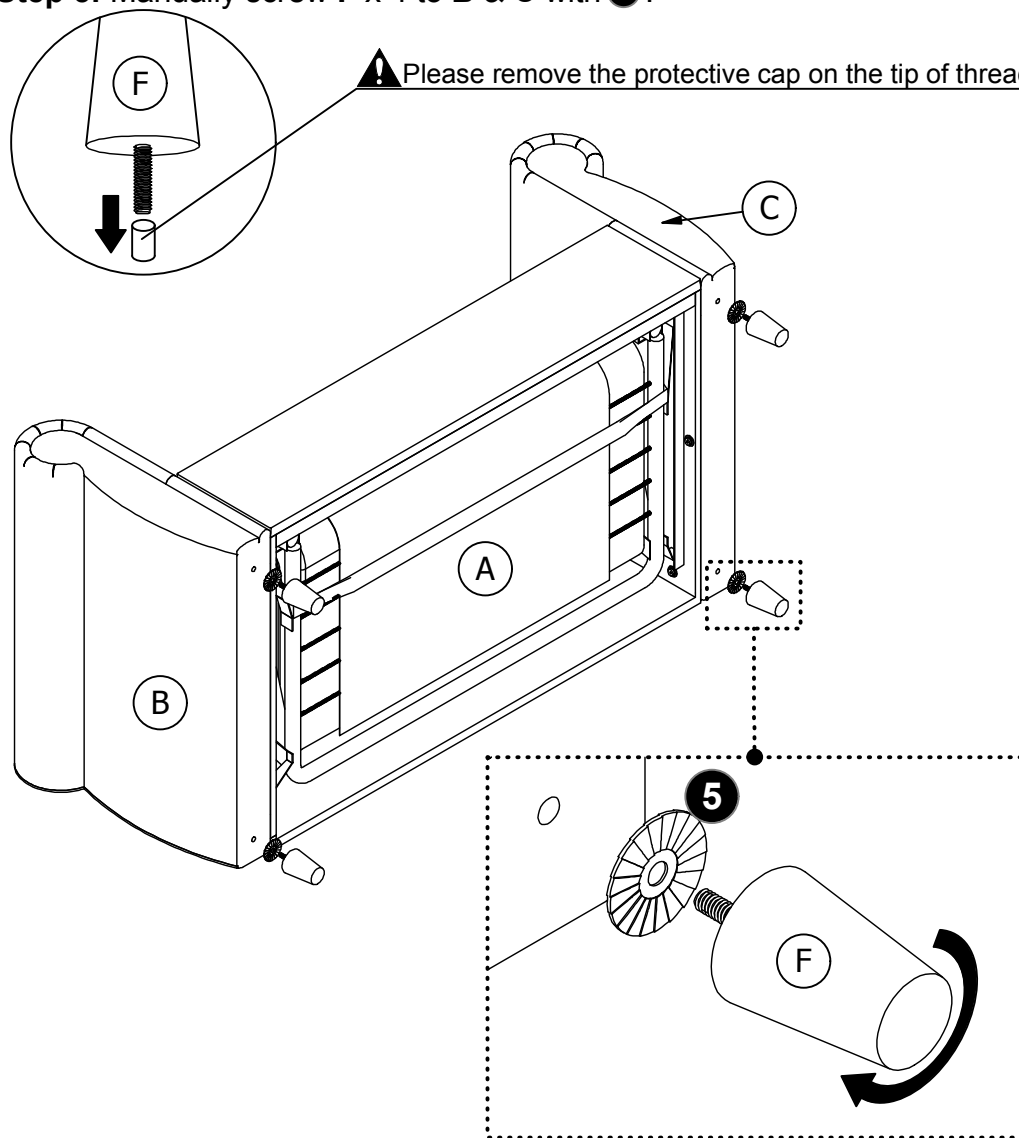

Step 6: Put D x 2 & E x 2 onto A, as shown.

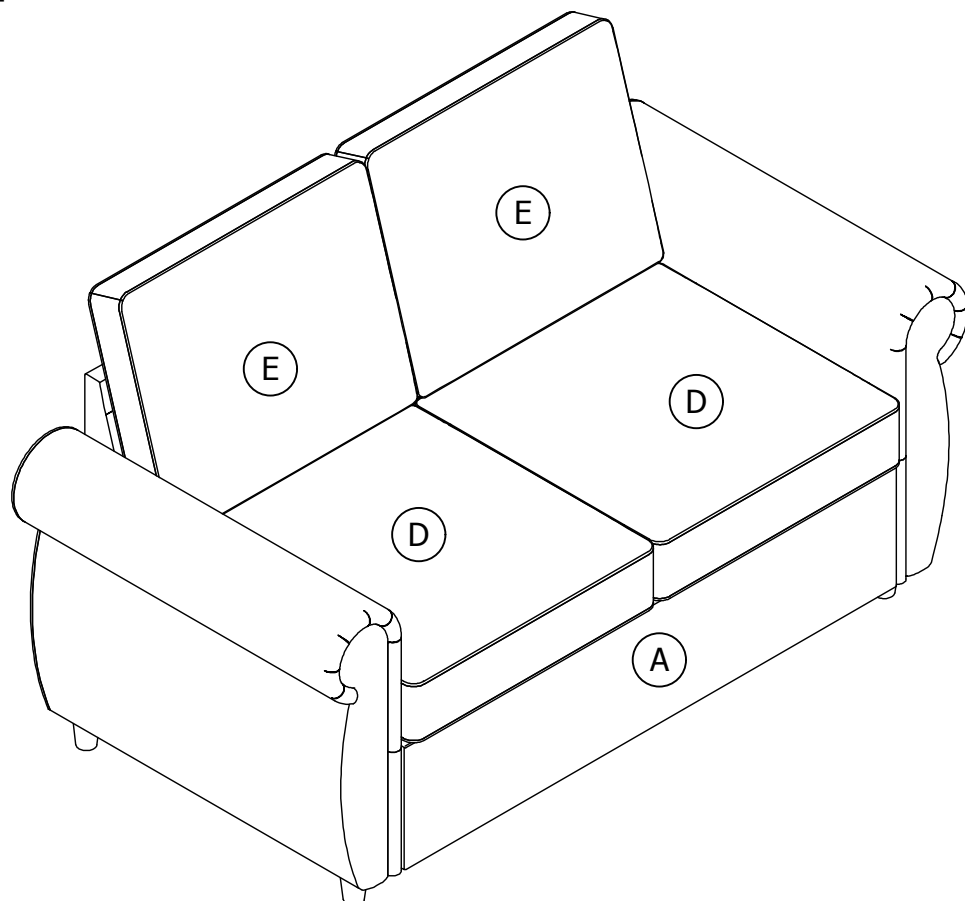

Helpful Hints

- Move your new furniture carefully, with two people lifting and carrying the unit to its new location.
- Your furniture can be disassembled and reassembled to move.
- Clean the product with a soft damp cloth. **DO NOT** use harsh chemicals or abrasive cleaners.
- Some parts have been pre-assembled for this item. They are illustrated on this page and available for replacement.

 Before opening for the first time, please cut the Tie-wraps located underneath the seat.

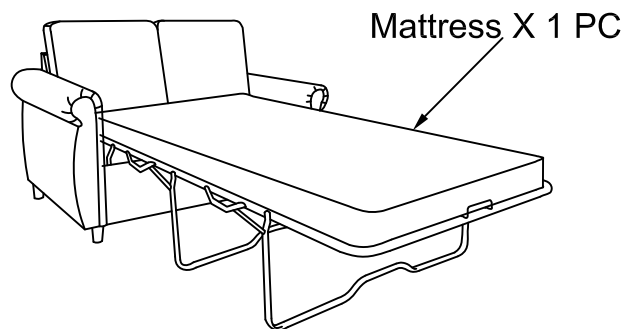
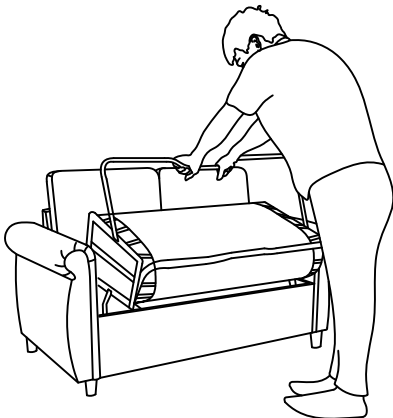
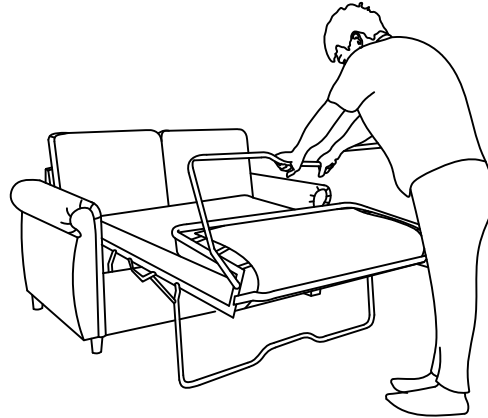
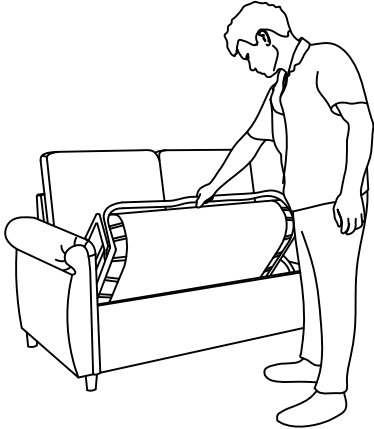

DO NOT fold while linens or cushions are on the mattress.

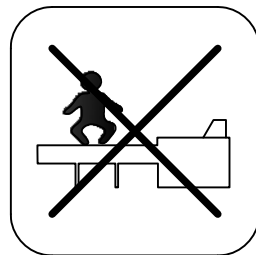

DO NOT jump on bed.
DO NOT allow children to open or close the sofa bed.

DO NOT allow children to play underneath sofa when in the bed position.