

INSTRUCTION

WF321613

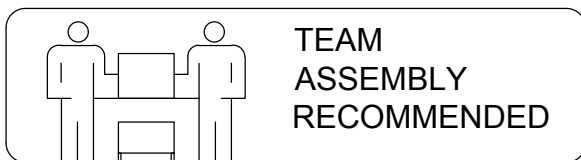
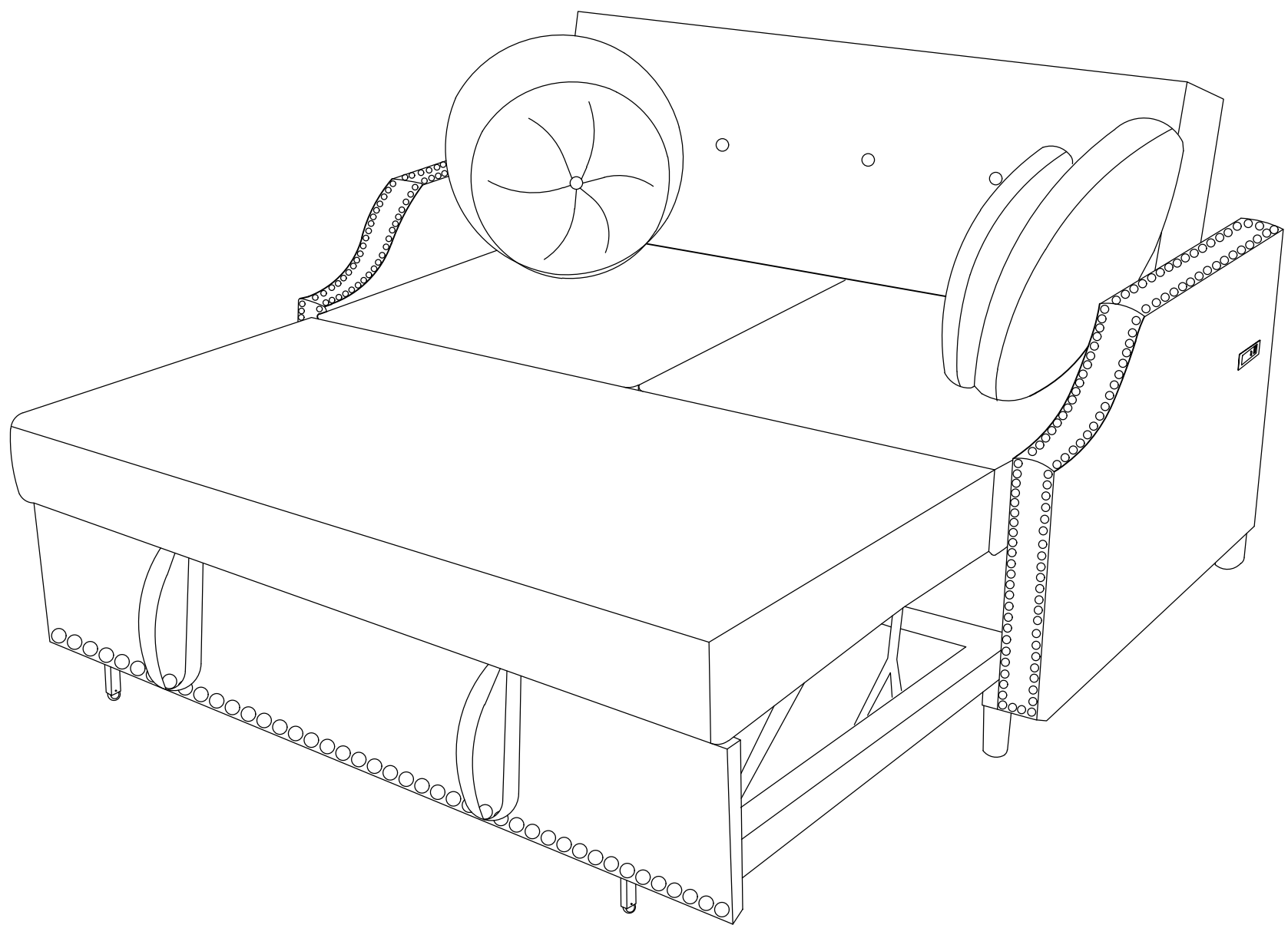

TEAM
ASSEMBLY
RECOMMENDED

SOFA BED



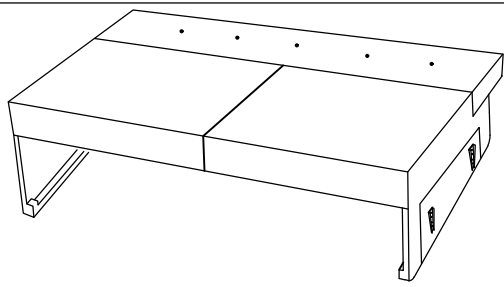
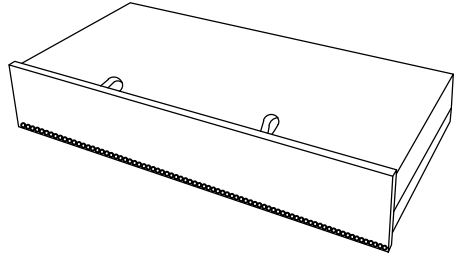
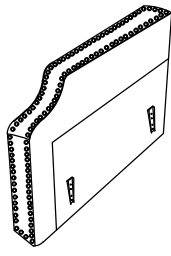
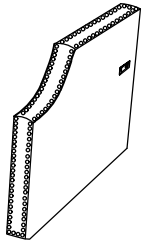
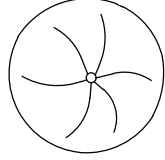
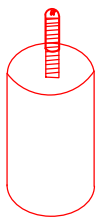
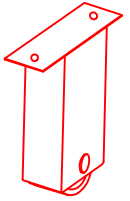
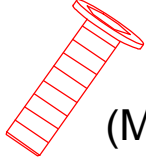
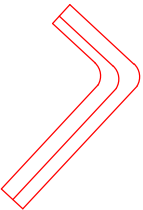
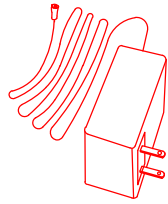
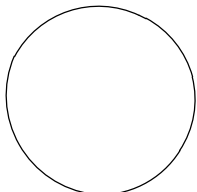

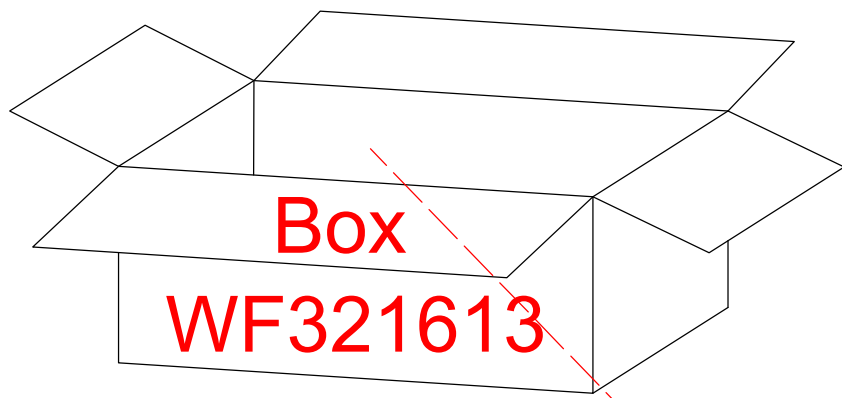

PARTS LIST

NO	PART	DECS	QTY
A		SEAT CUSHION	1pc
B		TRUNDLE BED	1pc
C		LEFT ARM	1pc
D		RIGHT ARM	1pc
E		PILLOW	2pc
F		LEGS	4pc
G		LEGS	4pc
H	 (M6*20MM)	SHORT SCREW	8pc
I		L-SHAPED WRENCH	1pc
J		USB POWER	1pc
K		PILLOW	2pc

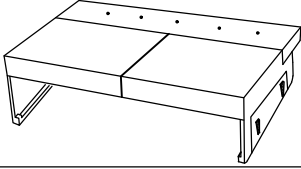
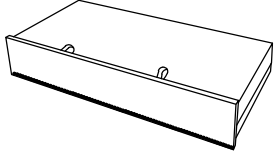
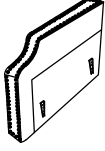
STEP 1

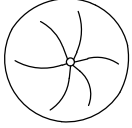
Ship by 1 box

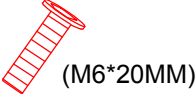

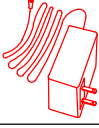
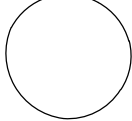
NO	PART	DECS	QTY
(A)		SEAT CUSHION	1pc
(B)		TRUNDLE BED	1pc
(C)		LEFT ARM	1pc
(D)		RIGHT ARM	1pc
(E)		PILLOW	2pc
(F)		LEGS	4pc
(G)		LEGS	4pc
(H)		SHORT SCREW	8pc
(I)		L-SHAPED WRENCH	1pc
(J)		USB POWER	1pc
(K)		PILLOW	2pc

STEP 2

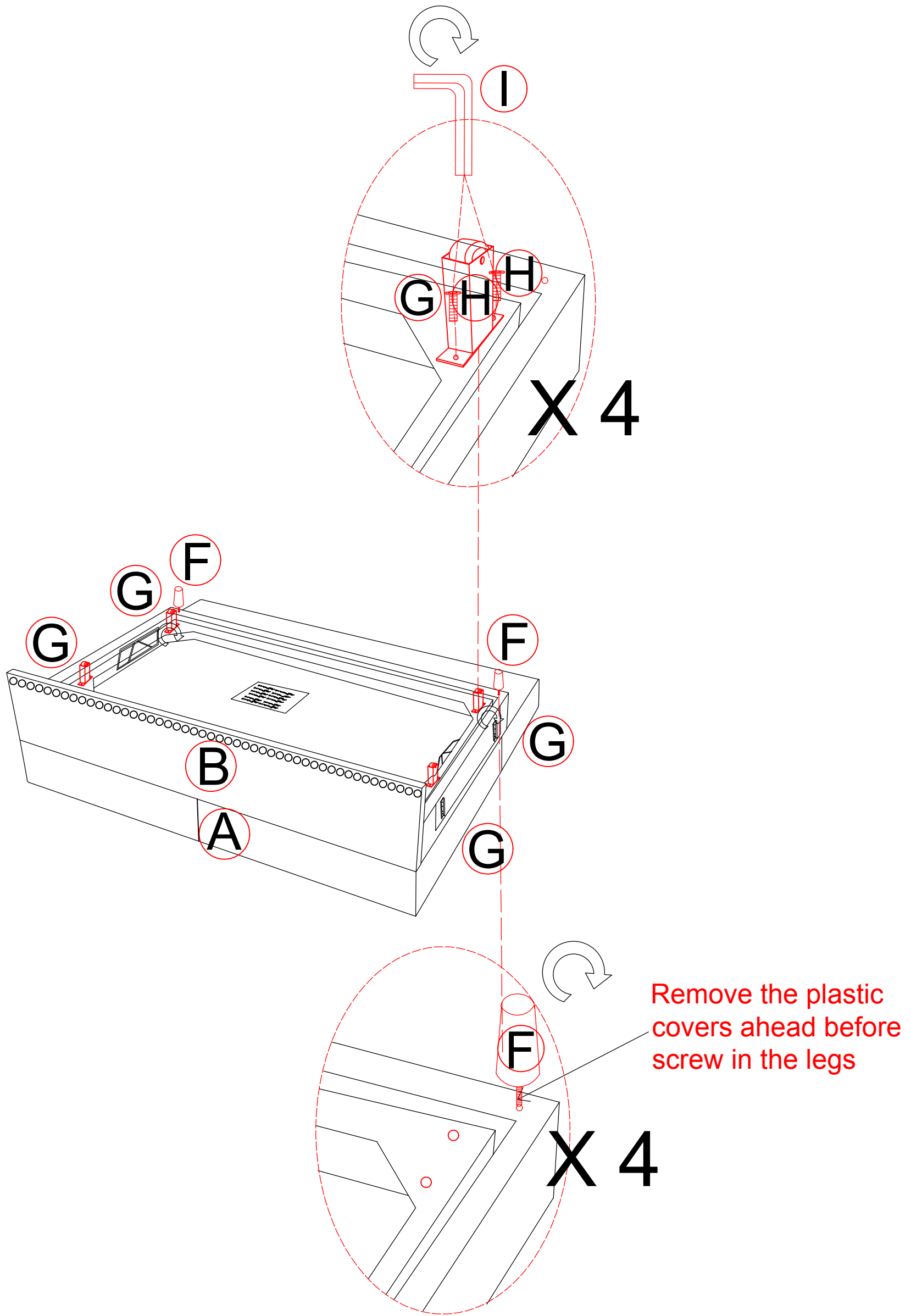

STEP 3

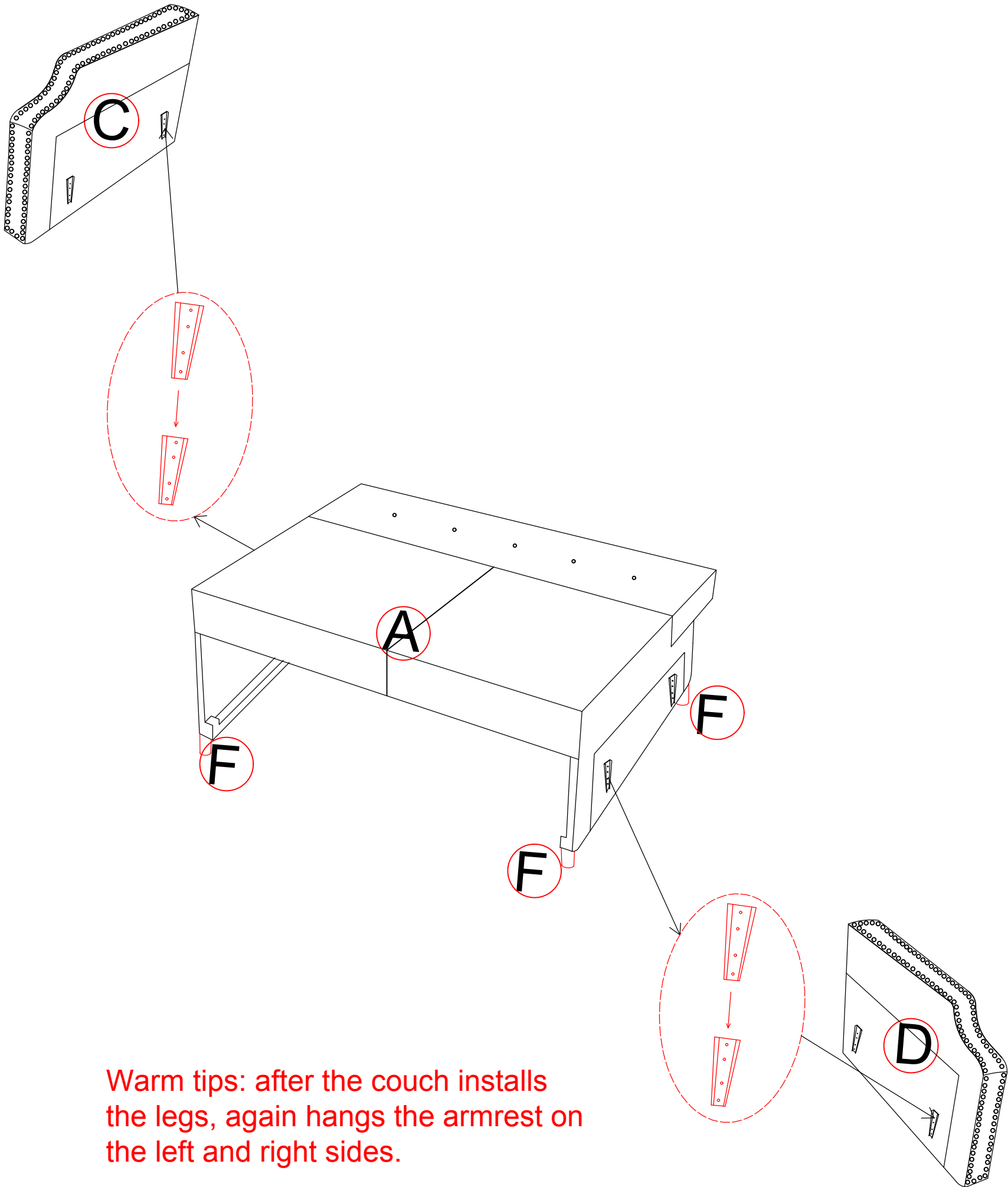

Warm tips: after the couch installs the legs, again hangs the armrest on the left and right sides.

STEP 4

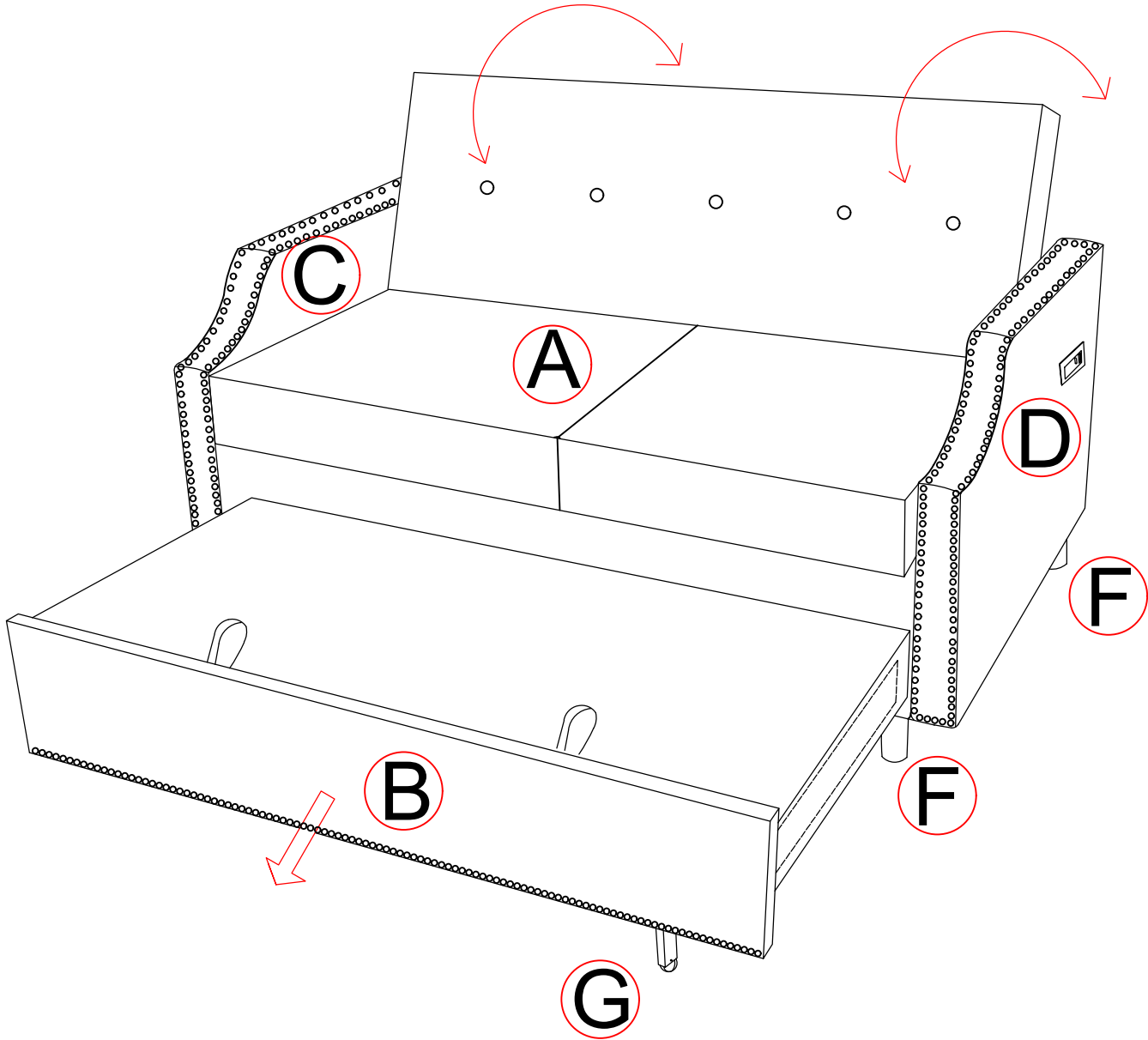

The trundle bed can be pulled out.

STEP 5

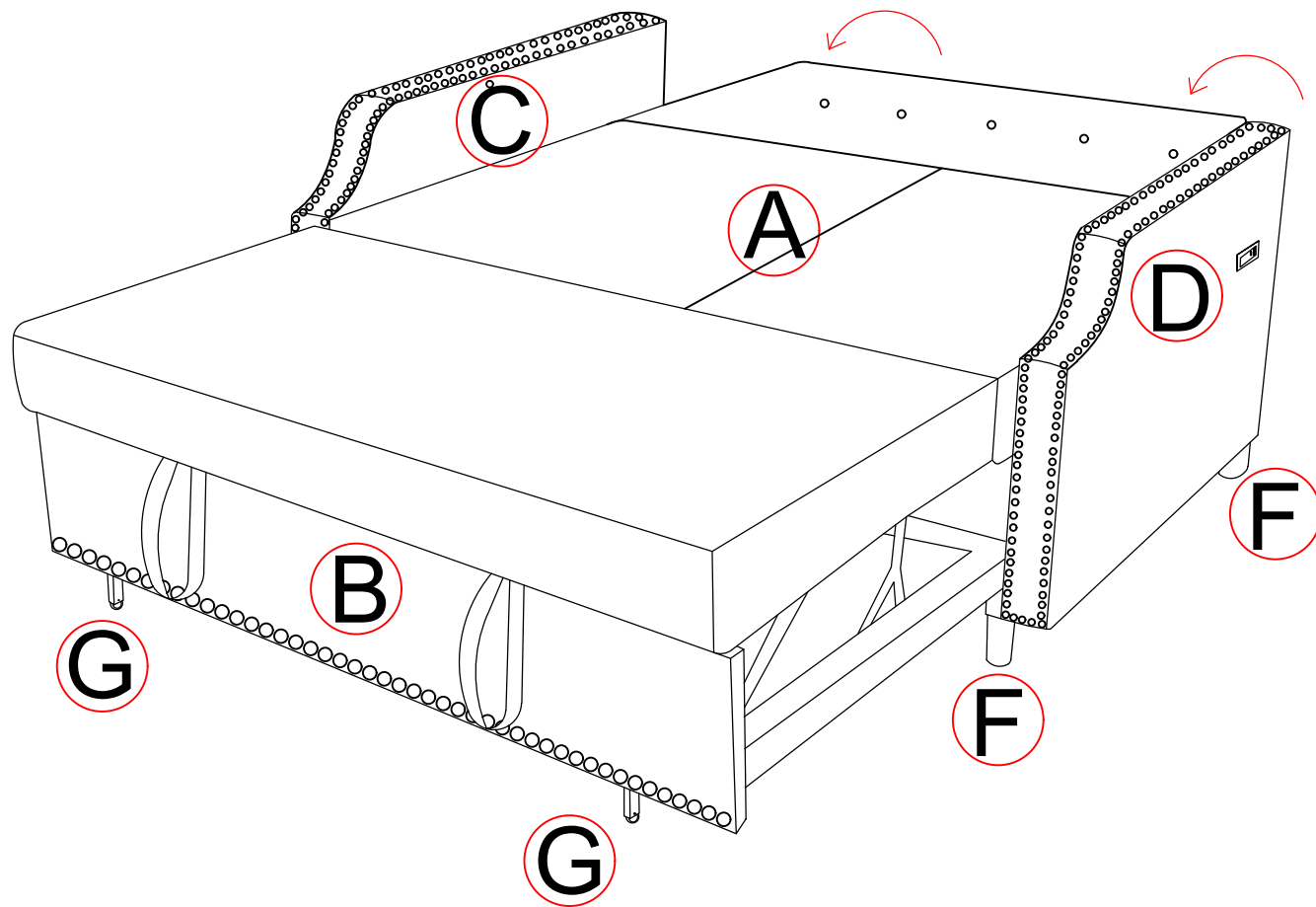

The backrest can be flat.

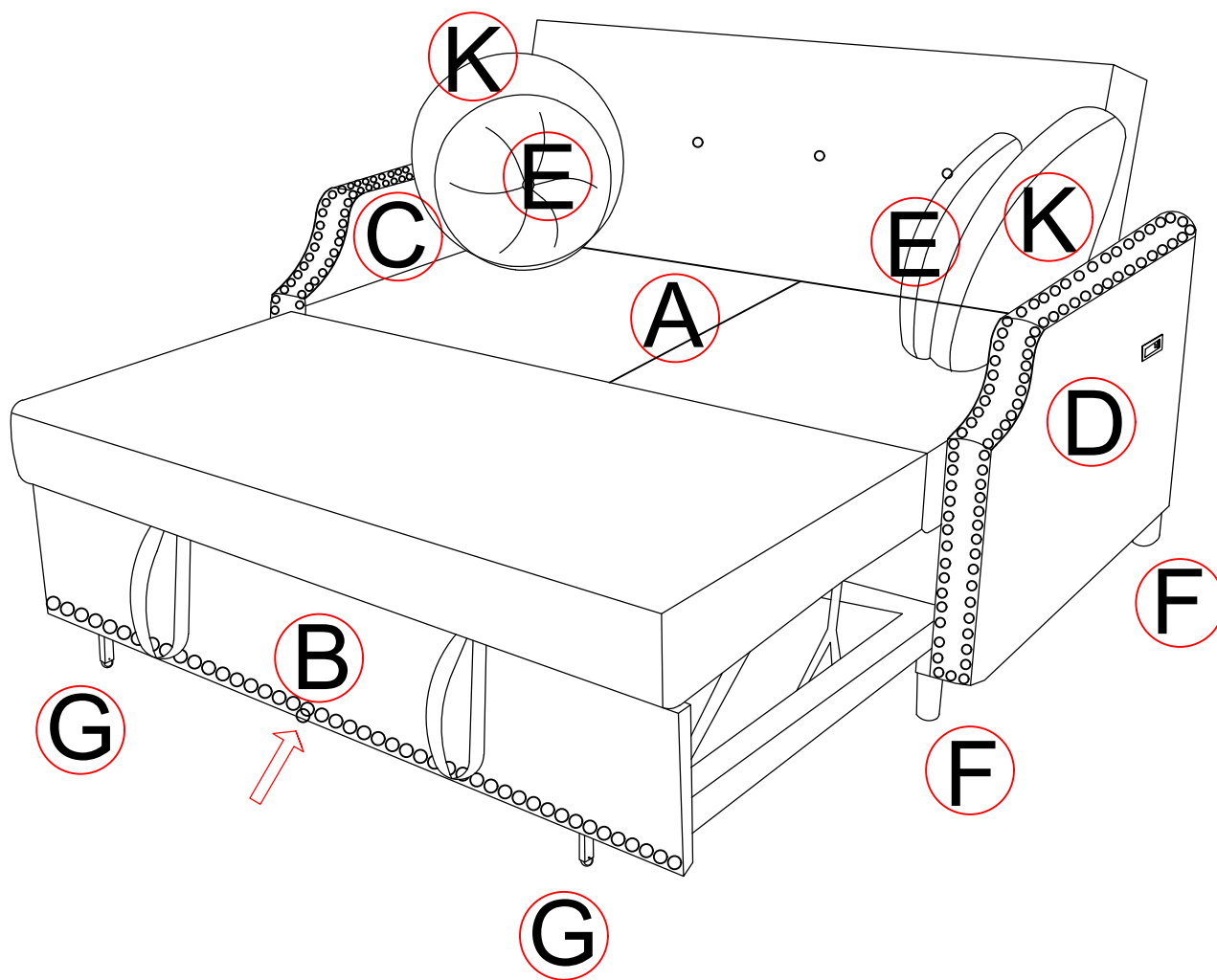

STEP 6

