

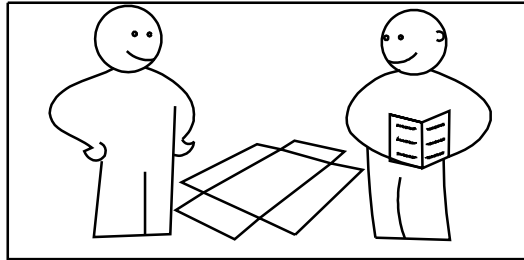

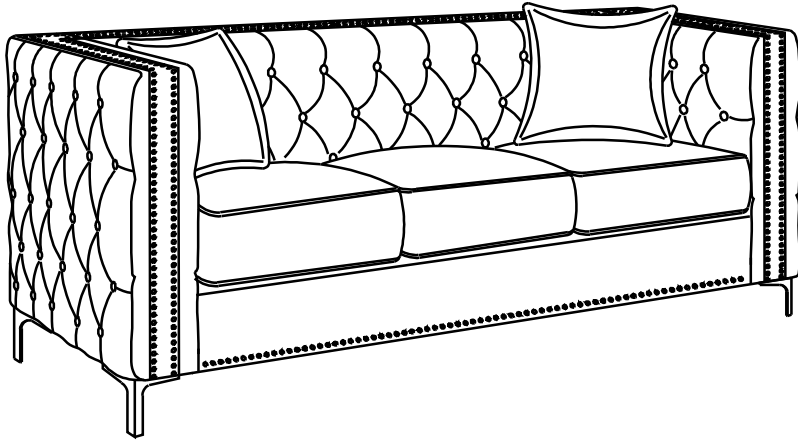

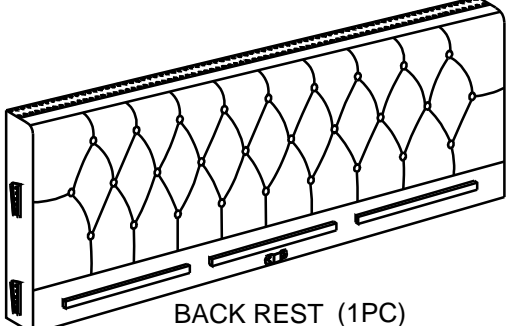

ASSEMBLY INSTRUCTION

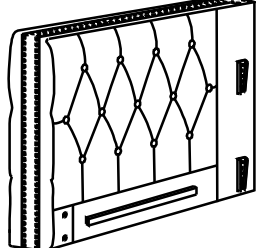
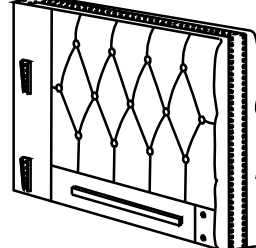

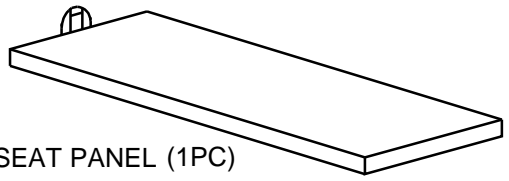
Attention:
Two people are required for assembly and lifting unit.

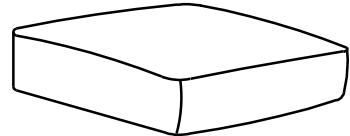
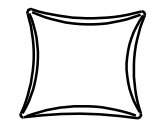
ASSEMBLY PART

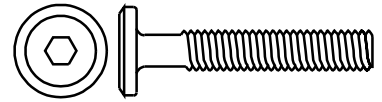
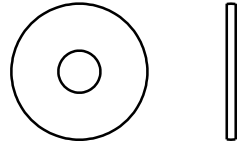
<p>1.</p>  <p>BACK REST (1PC)</p>	<p>2.</p>  <p>LEFT ARM (L) (1PC)</p>	<p>3.</p>  <p>RIGHT ARM (R) (1PC)</p>			
<p>4.</p>  <p>LEG (4PCS)</p>	<p>5.</p>  <p>FRONT RAIL (1PC)</p>	<p>6.</p>  <p>SEAT PANEL (1PC)</p>			
<p>7.</p>  <p>SEAT PANEL SUPPORT (1PC)</p>	<p>8.</p>  <p>SEAT CUSHION (3PCS)</p>	<p>9.</p>  <p>PILLOW (2PCS)</p>			
					
<p>A</p>	<p>1PC</p>	<p>B</p>	<p>8PCS</p>	<p>C</p>	<p>8PCS</p>
<p>Allen Key M4</p>		<p>JCBC Bolt M6 X 30mm</p>		<p>Flat Washer M6</p>	

ASSEMBLY INSTRUCTION

STEP 1.

For this step remove all the part and hardware.

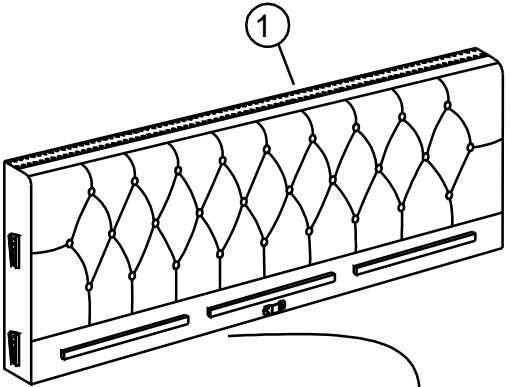
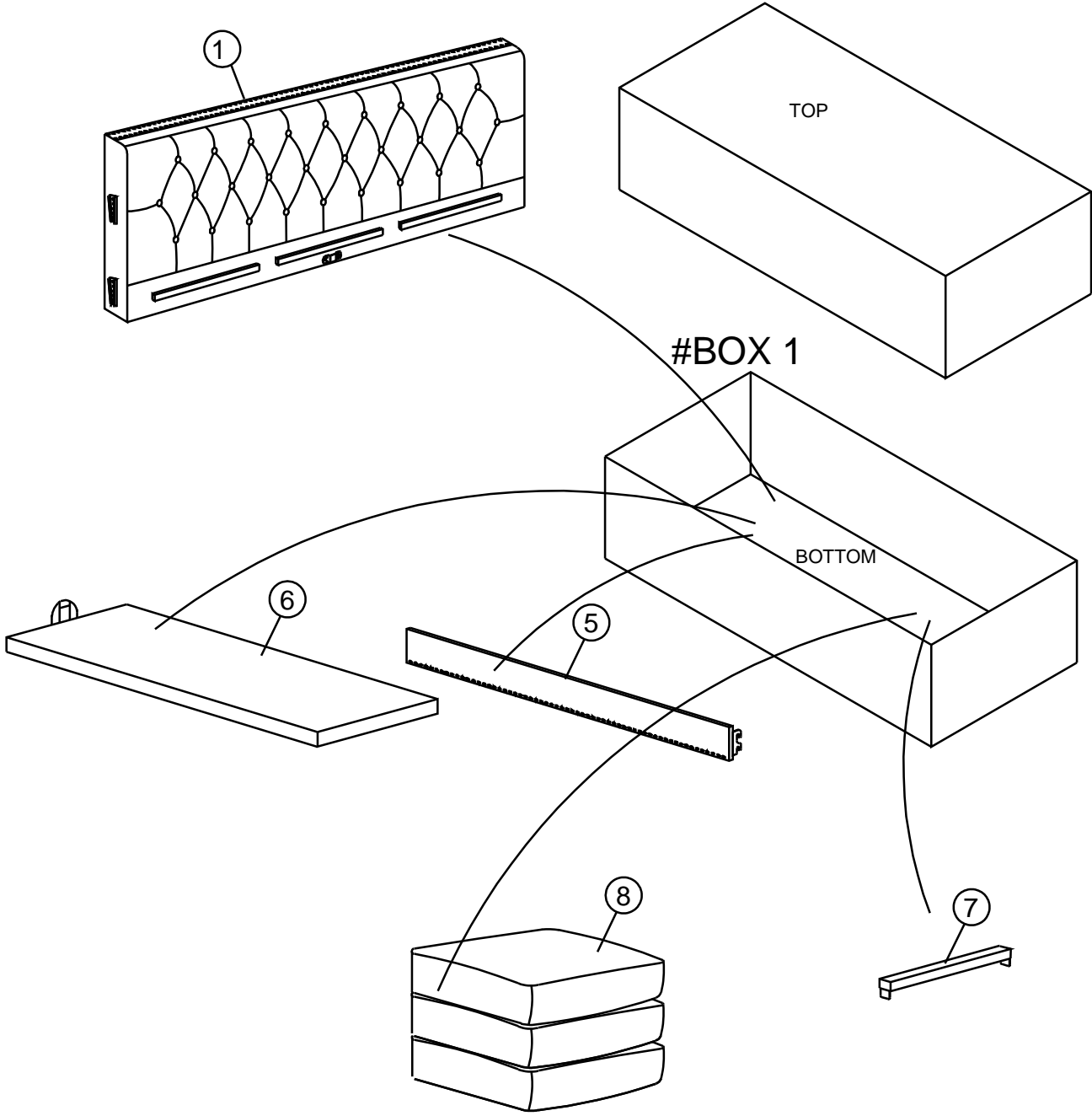

**Cushions, Legs and Hardware can be found on the bottom of sofa back rest.

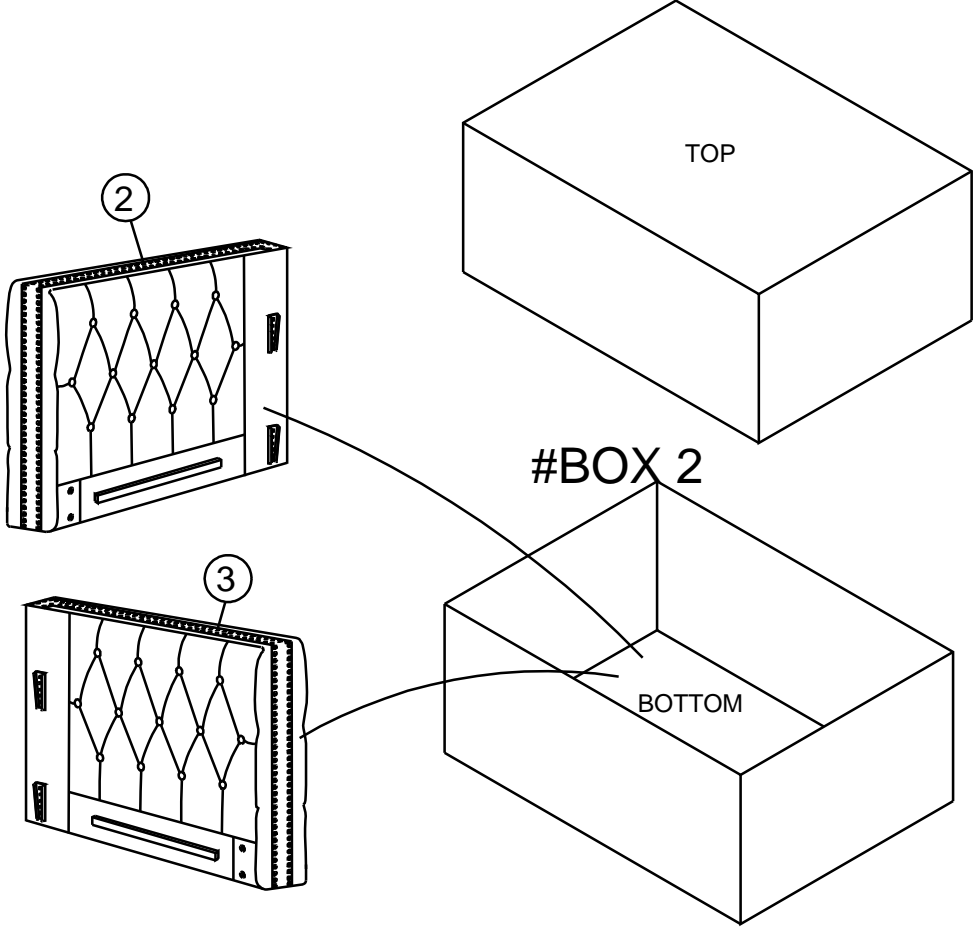
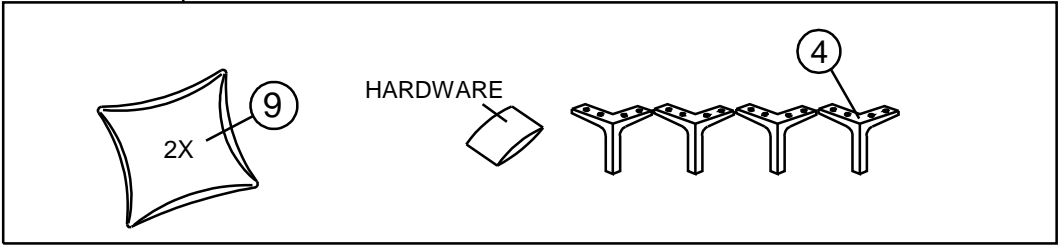

ASSEMBLY INSTRUCTION

STEP 2.

Attach Leg (4) (4pcs) to the Left Arm (L) (2) and Right Arm (R) (3). Legs are to be attached using JCBC Bolt M6 x 30mm (B) (8pcs), Flat Washer M6 (C) (8pcs), using Allen Key (A). Make sure bolt are fully tightened and secure.

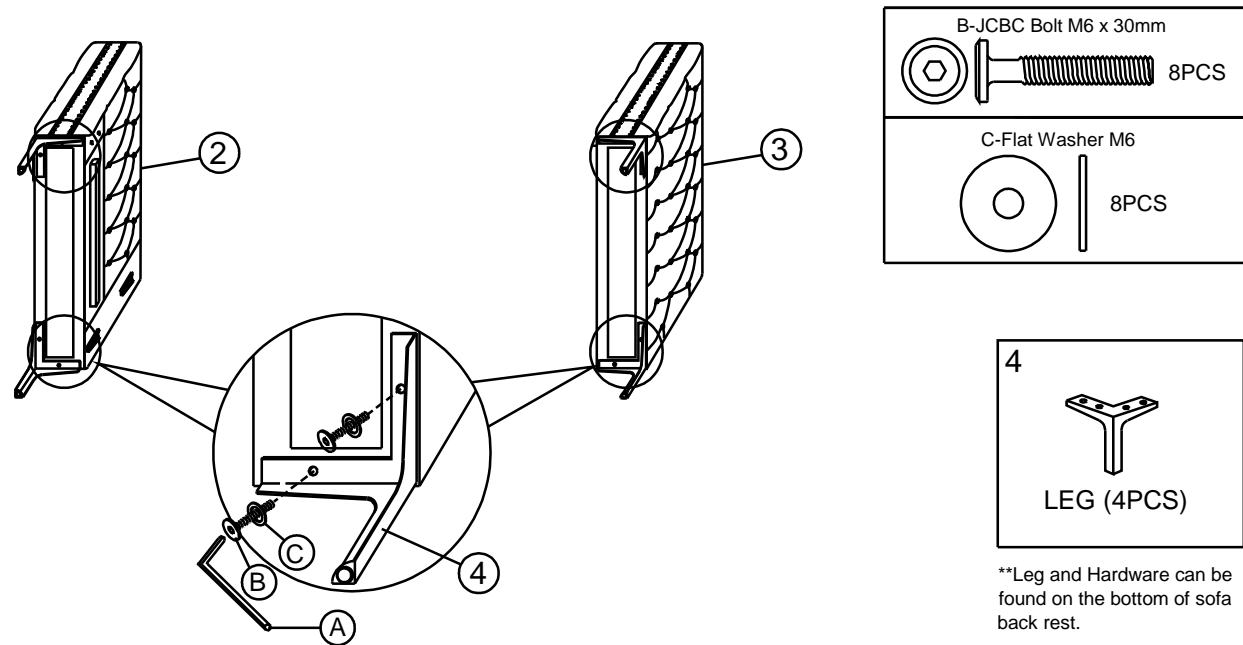

STEP 3.

Hook on the Back Rest (1) into Left Arm (2) and Right Arm (3) securely.

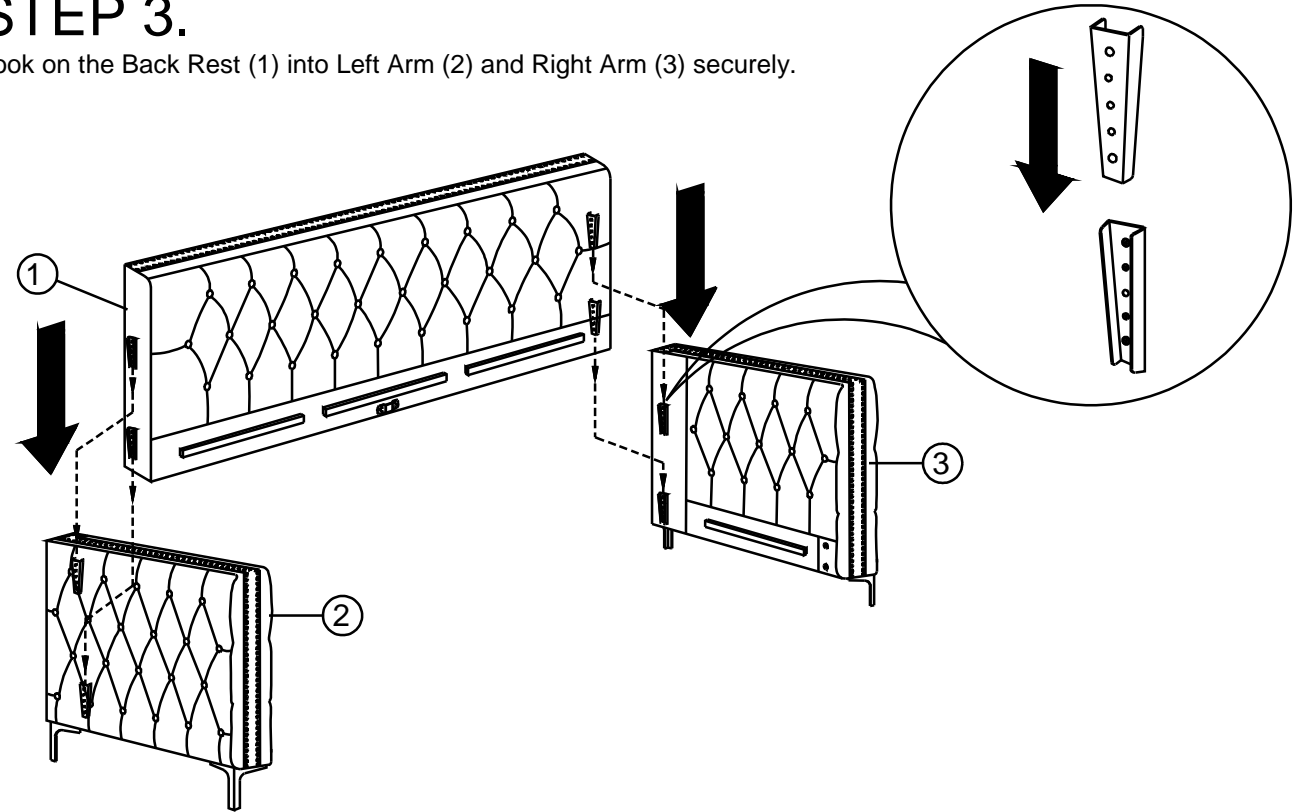

STEP 4.

Slightly loosen the four bolts using Allen Key (A) without removing the bolts completely from both Side Arms (2 and 3). Hook on Front Rail (5) hooks into loosen bolts, once placed tighten and secure all four bolt with Allen Key (A).

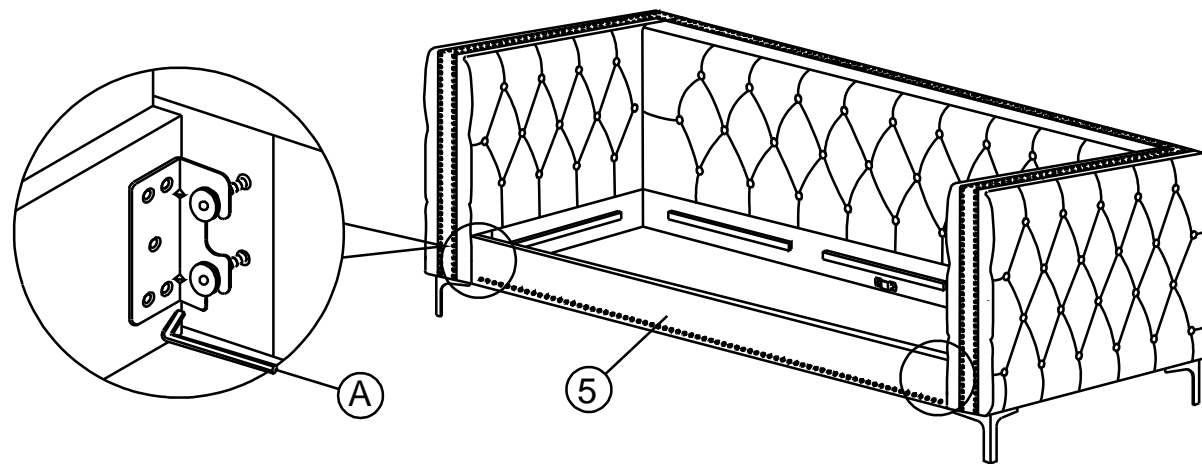

STEP 5.

Hook on and secure Seat Panel Support (7) to the two metal slots on both Front Rail (5) and Back Rest (1).

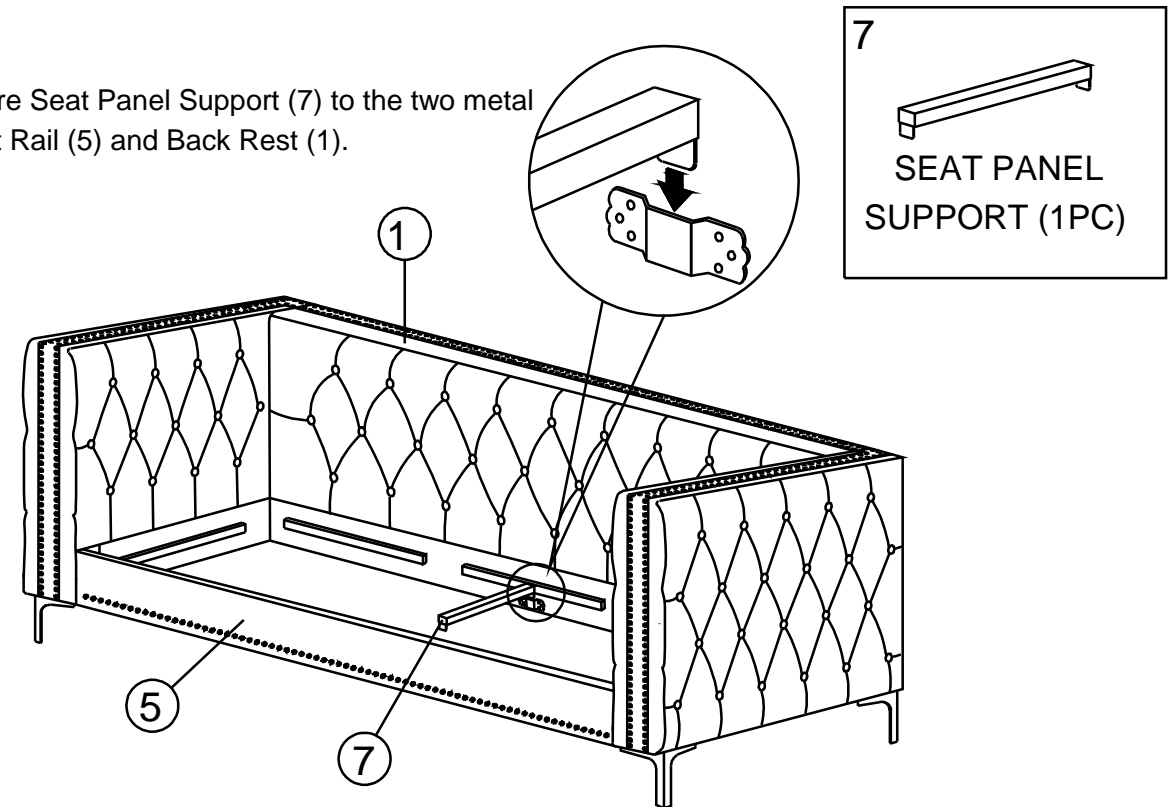

ASSEMBLY INSTRUCTION

STEP 6.

Lay the Seat Panel (6) on top of units frame.

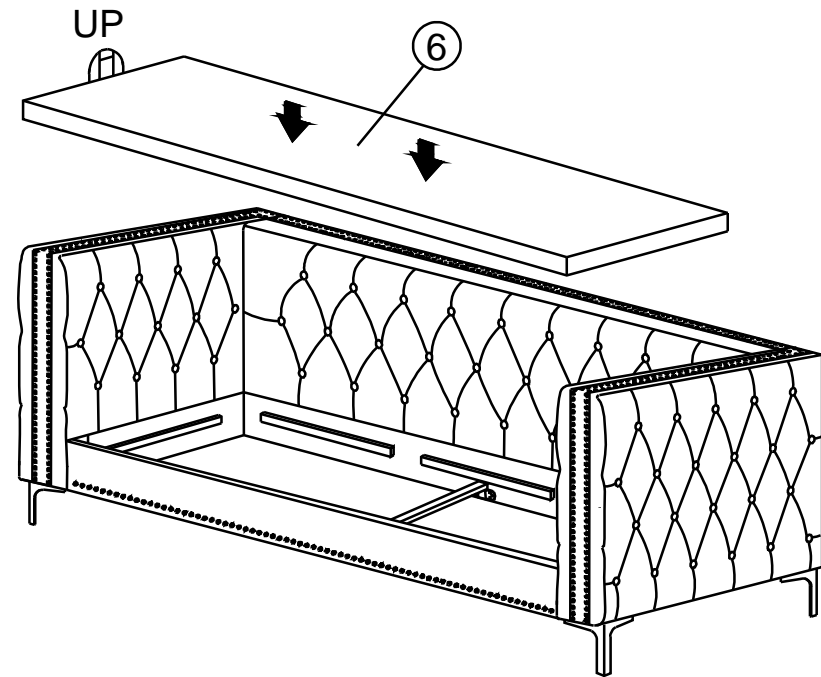

STEP 7.

Attach the Seat Cushion (8) (2pcs).

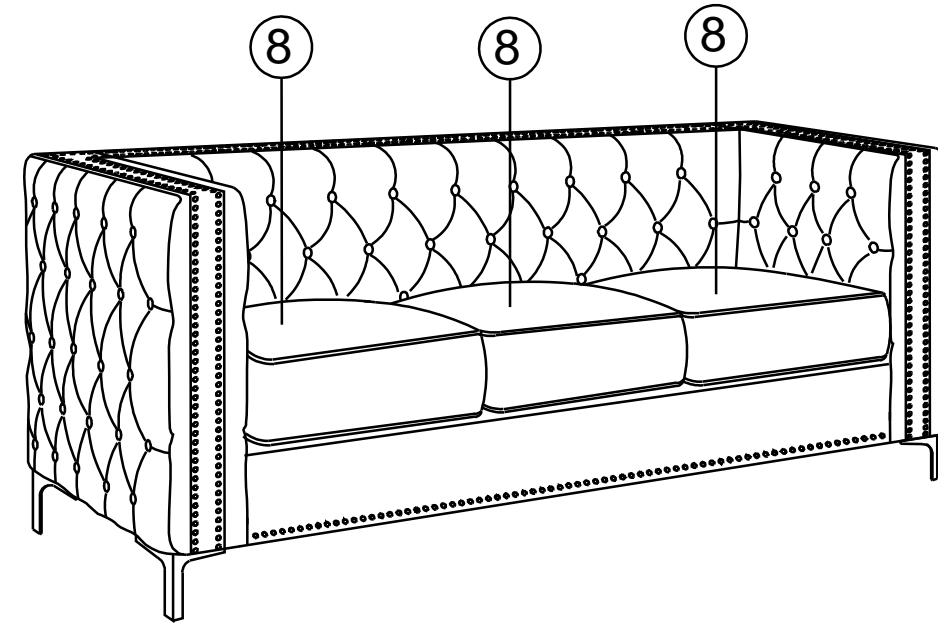

STEP 8.

Lay Pillows (9) (2pcs).

