

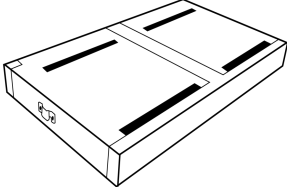
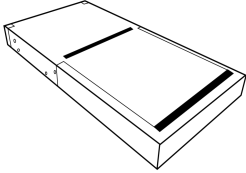
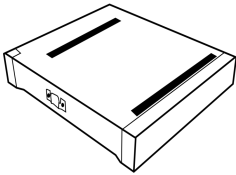
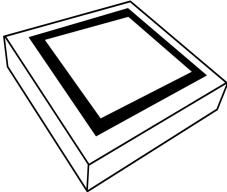
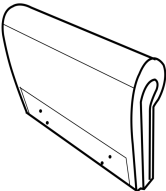
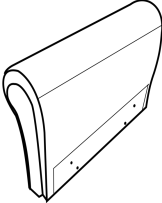
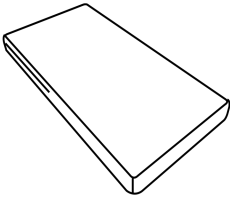
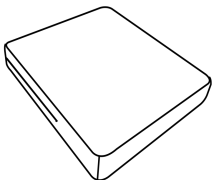
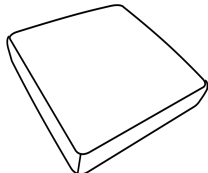
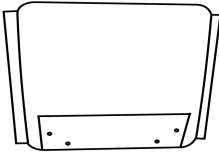
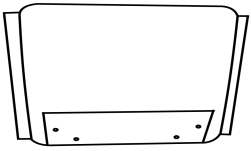
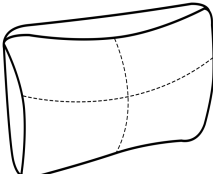
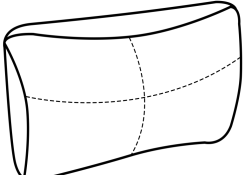
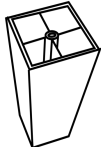
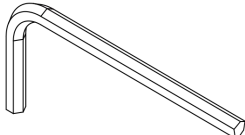
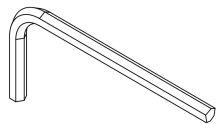
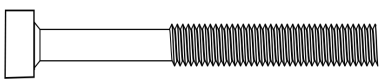
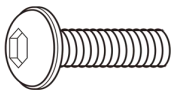
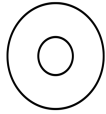
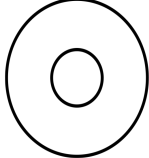
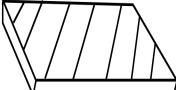

# Assembly Instruction

## Parts List

NO	Picture	Description	QTY
A		Left Seat Base	1PC
B		Right Seat Base	1PC
C		Middle Seat Base	1PC
D		Ottoman Seat Base	1PC
E		Left Arm	1PC
F		Right Arm	1PC
G		Seat Cushion	1PC
H		Seat Cushion	3PCS

NO	Picture	Description	QTY
I		Seat Cushion	1PC
J		Seat Back	3PCS
K		Seat Back	1PC
L		Back Cushion	3PCS
M		Back Cushion	1PC
N		Legs	17PCS
O		M7 Allen Wrench	1PC
P		M5 Allen Wrench	1PC
Q		M8x130mm Screw	17PCS
R		M8x35mm Screw	24PCS
S		Φ16mm Washer	17PCS

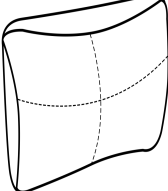
NO	Picture	Description	QTY
T		Φ22mm Washer	24PCS
U		Gasket	17PCS
V		Plastic Washer	17PCS
W		Pillow	2PCS

## Assembly Steps

### STEP 1

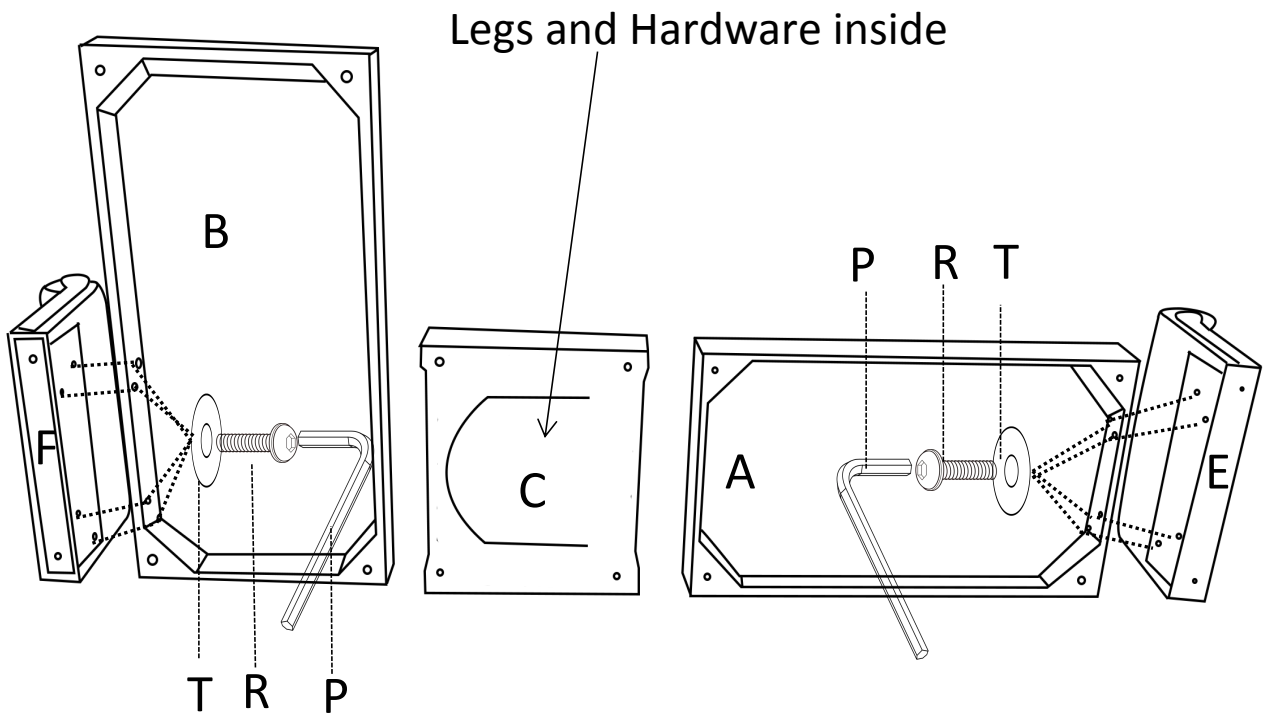

Attach the Right Arm (F) and the Left Arm (E) to the Seat Base using (8) M8x35mm screws (R) and (8) Φ22mm Washers (T), tighten with the M5 Allen Wrench (P).

## STEP 2

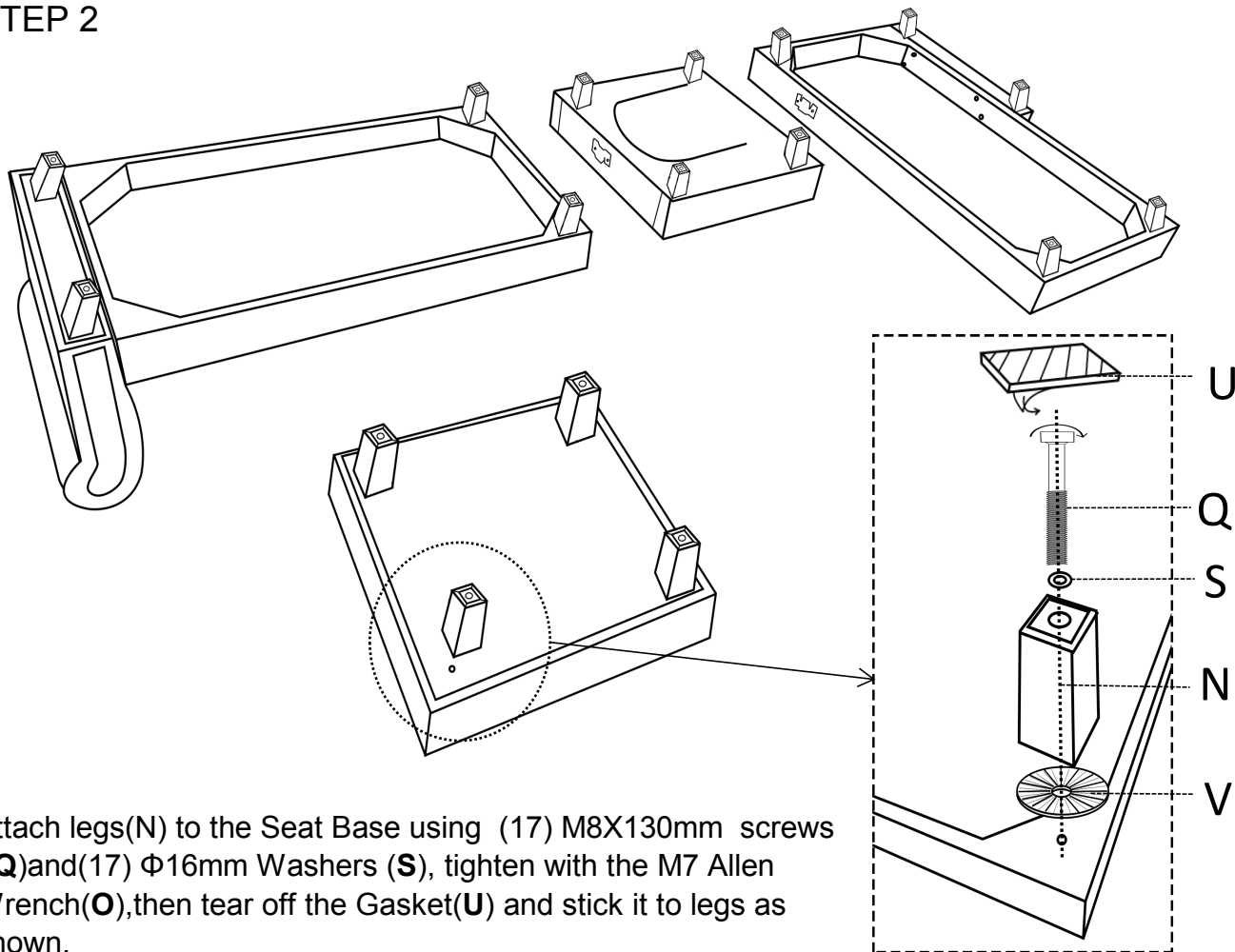

Attach legs(N) to the Seat Base using (17) M8X130mm screws (Q) and (17)  $\Phi$ 16mm Washers (S), tighten with the M7 Allen Wrench(O), then tear off the Gasket(U) and stick it to legs as shown.

## STEP 3

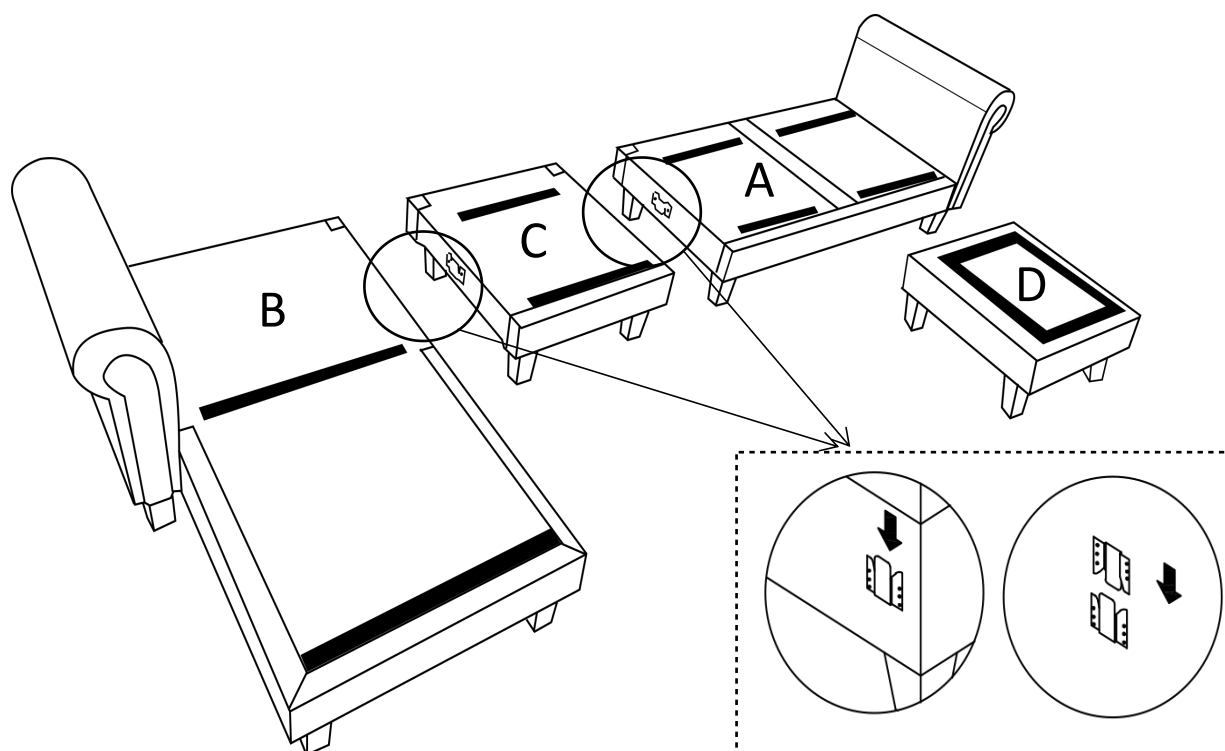

Connect the left seat base(A) and the right seat base(B) to the middle seat base(C) as shown.

## STEP 4

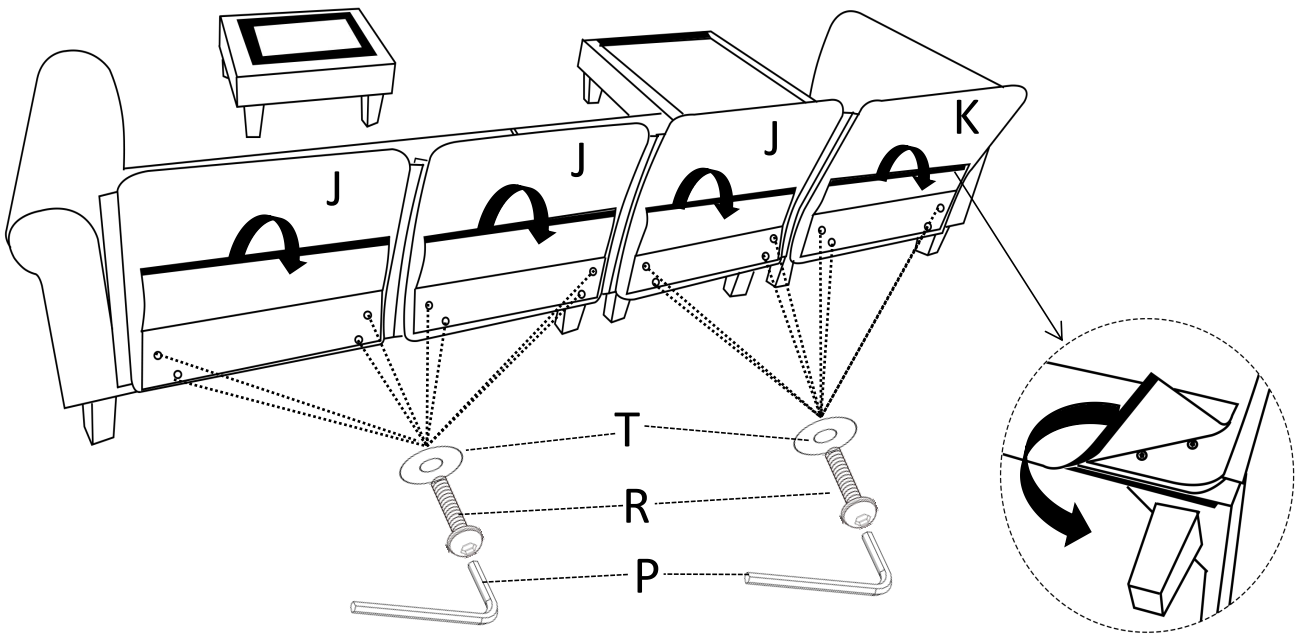

Attach the Seat Back to the Seat Base and align the holes to install the Seat Back, then put Velcro pieces together.

## STEP 5

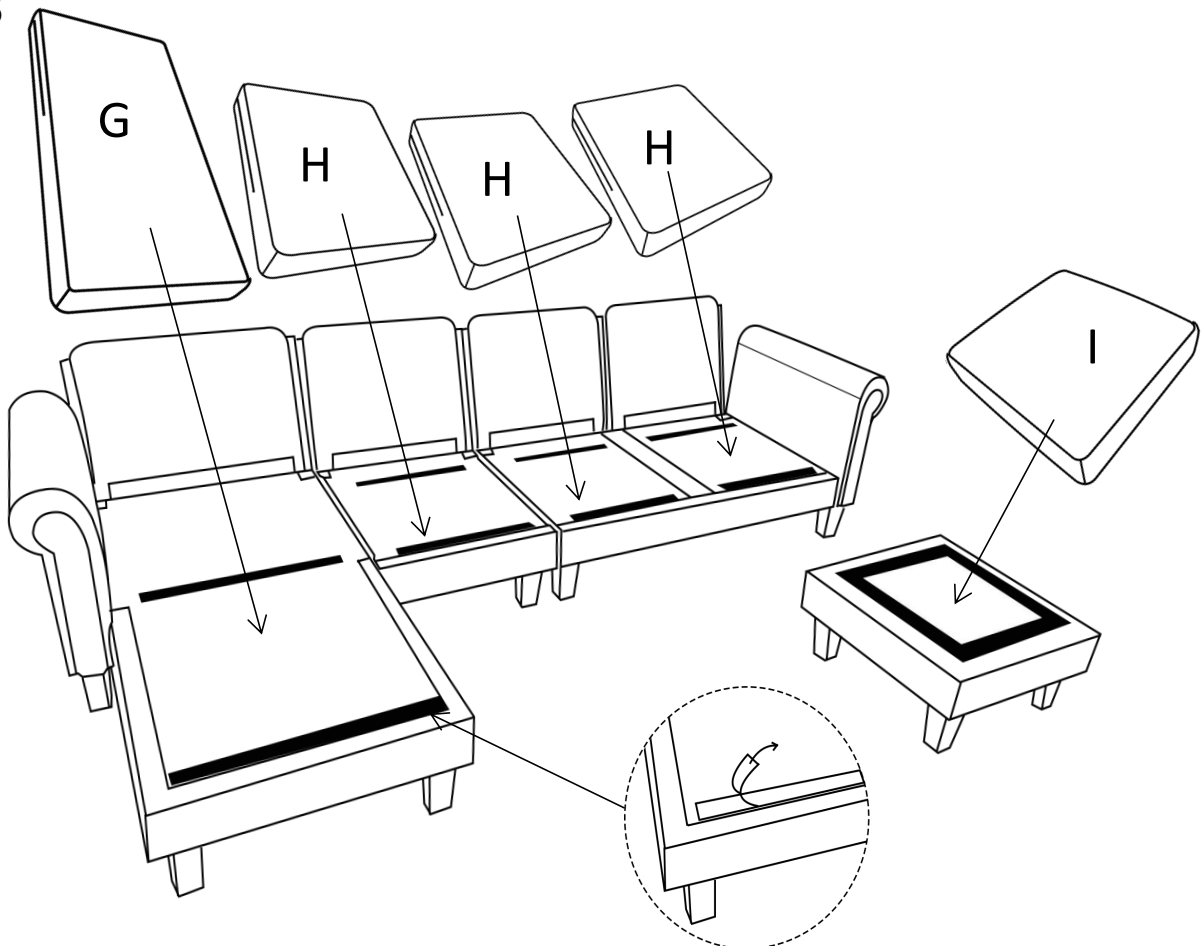

Tear off the Velcro protective cloth, then Attach the Seat Cushion into the Seat base as shown.

STEP 6

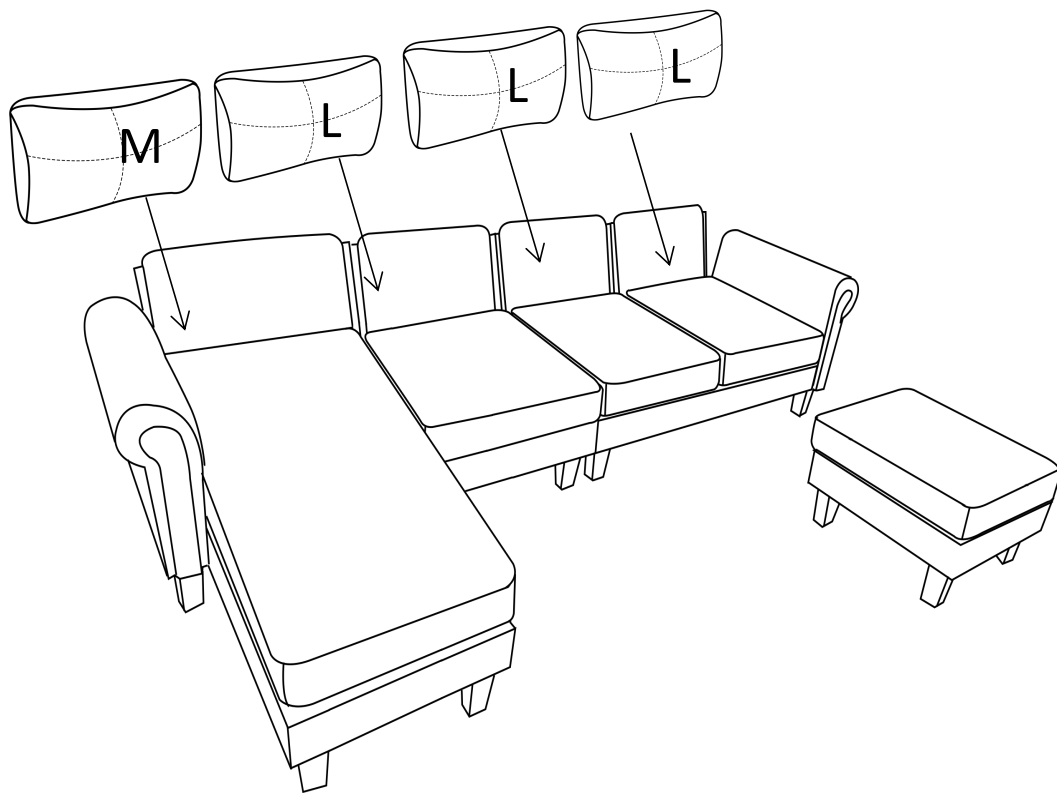

Lay the back cushion on the seat back as shown.

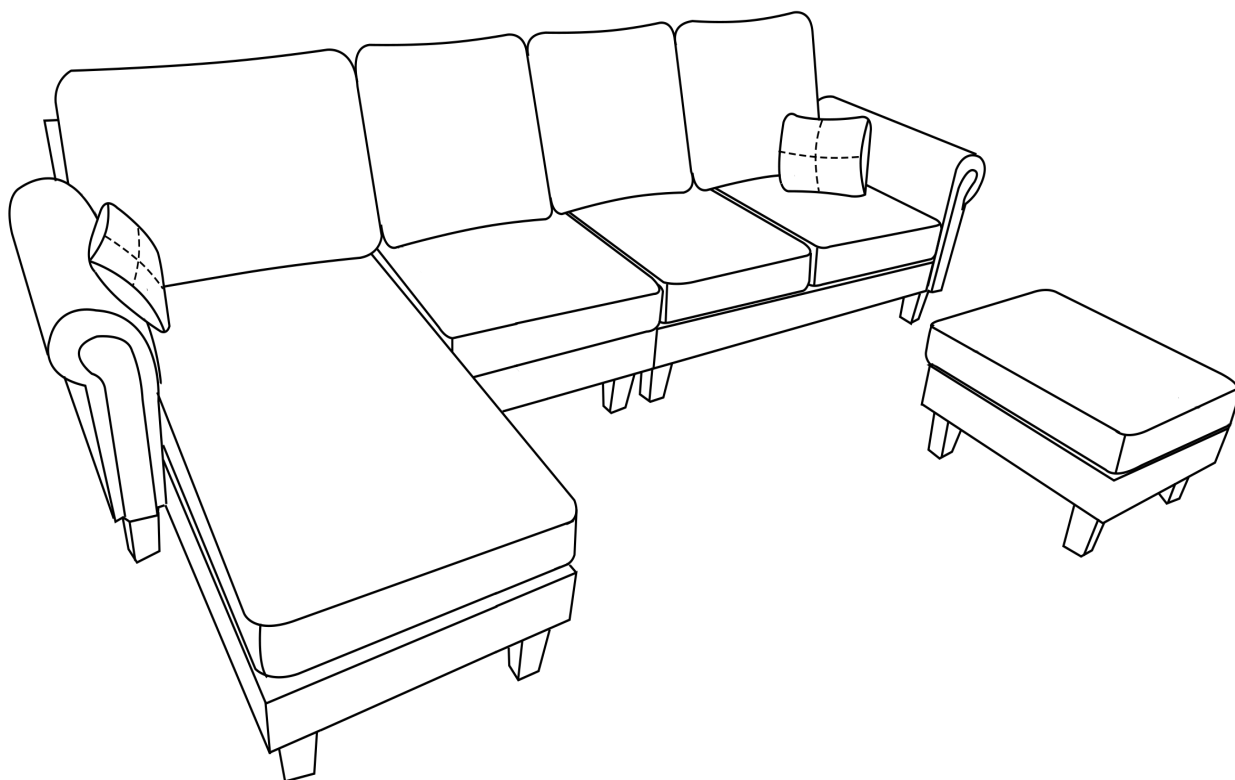

**FINISH!**