

ASSEMBLY INSTRUCTION

WF322221

WF322222

WF322223



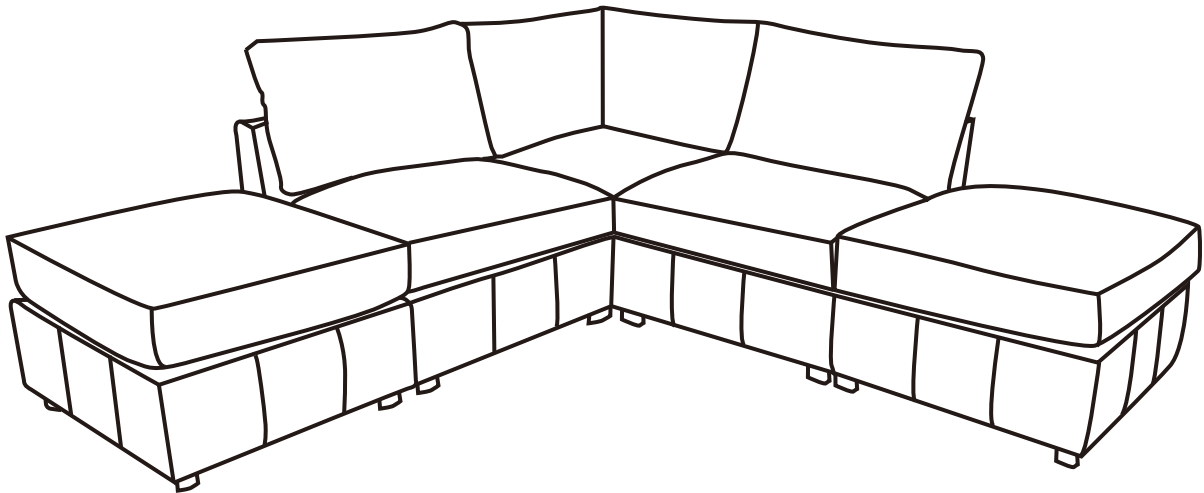

WF322224





Return & Warranty policy:

- We strive to offer the highest quality products, and we also try our best to satisfy each and every customer that orders from us with replacement parts or service as needed.
- If the item is damaged or defective, please take photos as evidence for replacements and refunds.
- Please do not return to store, contact the seller if you have any troubles with this product.

HARDWARE WF322224

NO	DESCRIPTION	SKETCH	QTY
1	Plastic Legs		20
2	Hex Key		1
3	Screws		16
4	Gasket		16
5	Feet Decals		20

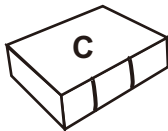
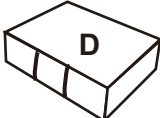
PARTS LIST WF322221

NO	DESCRIPTION	SKETCH	QTY
C	Seat Frame (left)		1
D	Seat Frame (right)		1
G	Cushion		2



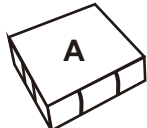
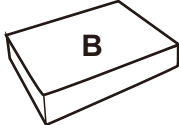

PARTS LIST WF322222

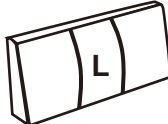
NO	DESCRIPTION	SKETCH	QTY
A	Ottoman Frame		2
B	Ottoman Cushion		2

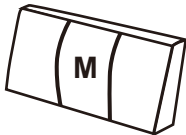

PARTS LIST WF322223

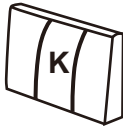
NO	DESCRIPTION	SKETCH	QTY
L	Backrest (left)		1

PARTS LIST WF322223



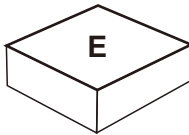
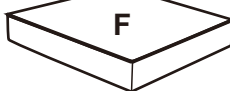
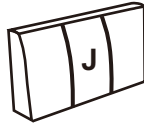

NO	DESCRIPTION	SKETCH	QTY
M	Backrest (right)		1
H	Back Cushion		2
K	Corner R Backrest		1
I	Corner Back Cushion		1

PARTS LIST WF322224

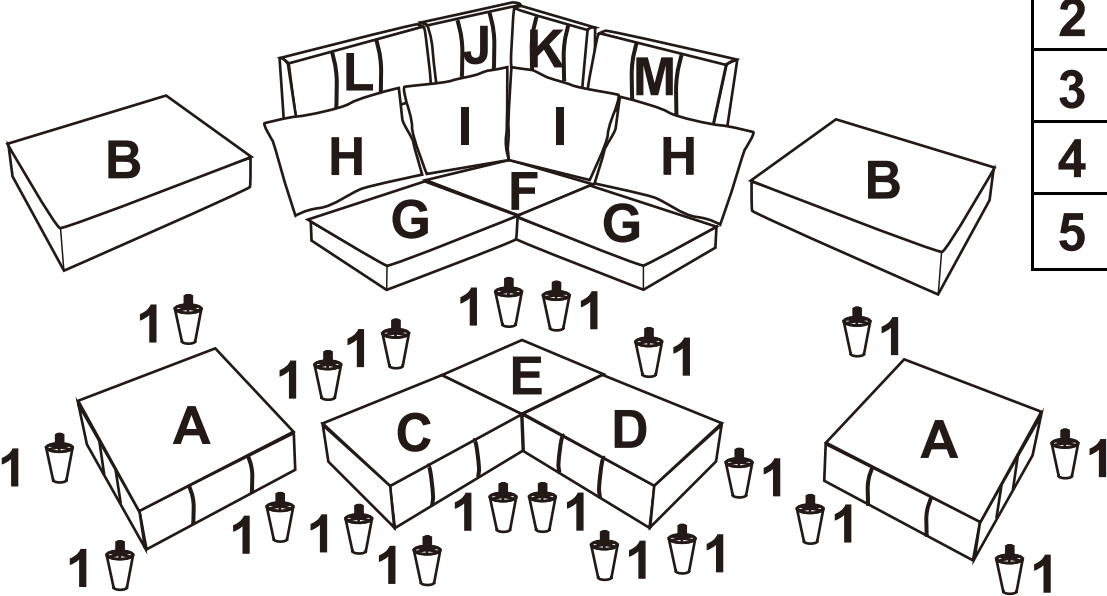
NO	DESCRIPTION	SKETCH	QTY
E	Corner Seat Frame		1
F	Corner Cushion		1
J	Corner L Backrest		1
I	Corner Back Cushion		1

All parts and hardwares



2		1
3		16
4		16
5		20

3/8

DIAGRAM 1

Take the ottoman cushions (Part B) out of the ottoman frames (Part A);
 Take the cushions (Part G) out of the seat frames (Part C & Part D);
 Take the corner cushion (Part F) out of the corner seat frame (Part E).

Take the back cushions (Part H) out of the backrests (Part L & Part M);
 Take the corner back cushions (Part I) out of the corner backrests (Part J & Part K).

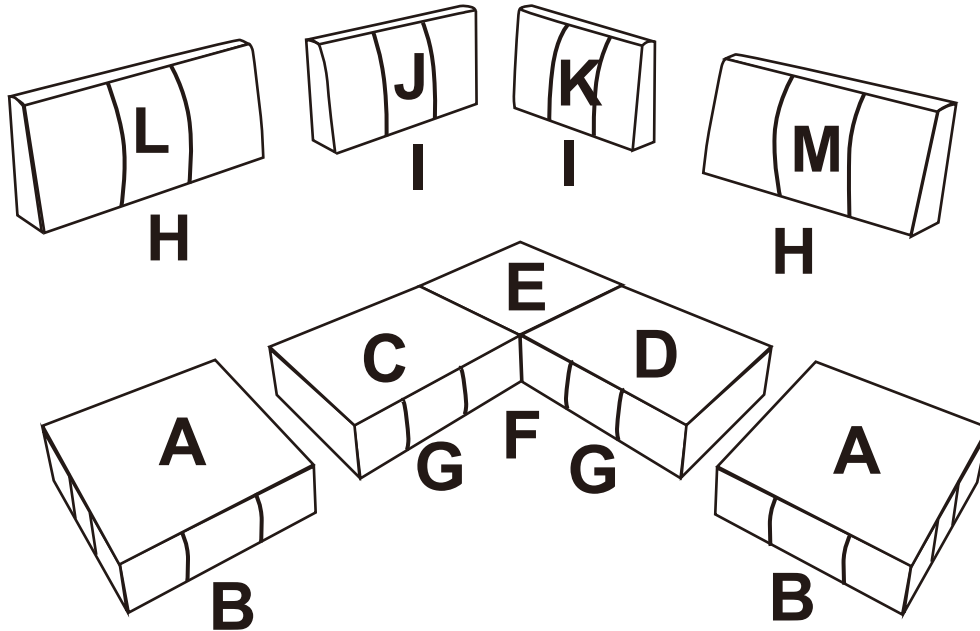
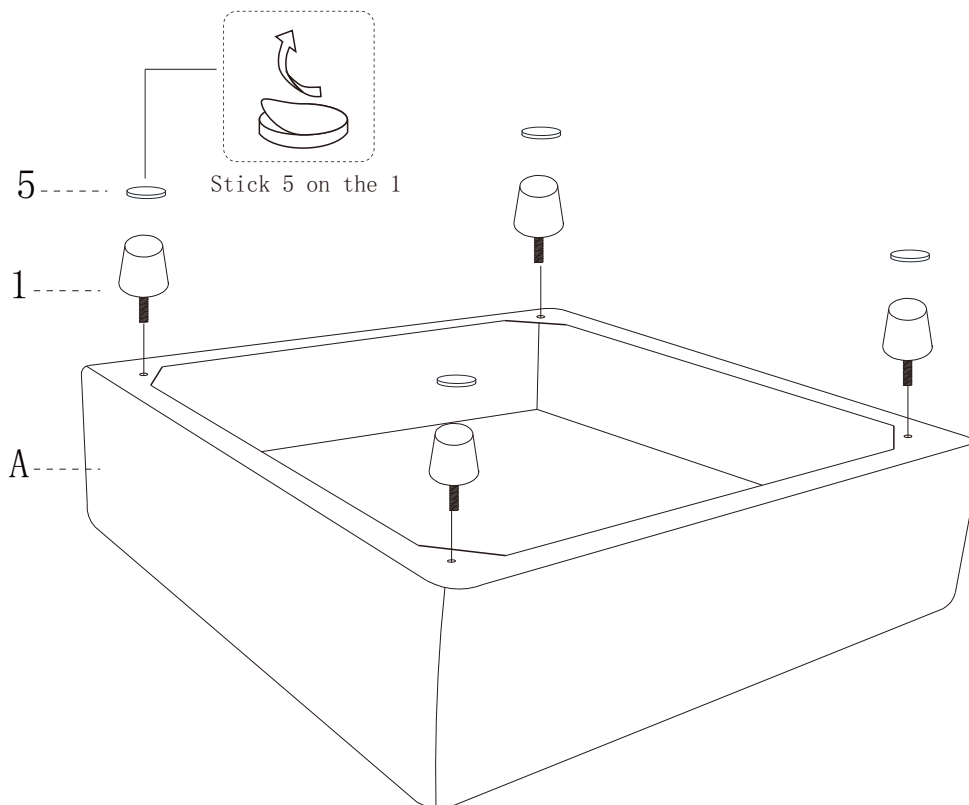

DIAGRAM 2

Tighten 4 plastic legs (Part 1), and stick the feet decal (Part 5) onto each leg.

1		8
5		8







x2

DIAGRAM 3

Connect the seat frame (left) (Part C) and backrest (left) (Part L) with the screws (Hardware 3) and gasket (Hardware 4) by hex key (Hardware 2). Tighten plastic 4 legs (Part 1), and stick the feet decal (Part 5) onto each leg.

Connect the seat frame (right) (Part D) and backrest (right) (Part M) with the screws (Hardware 3) and gaskets (Hardware 4) by hex key (Hardware 2). Tighten 4 plastic legs (Part 1), and stick the feet decal (Part 5) onto each leg.

1		8
2		1
3		8
4		8
5		8

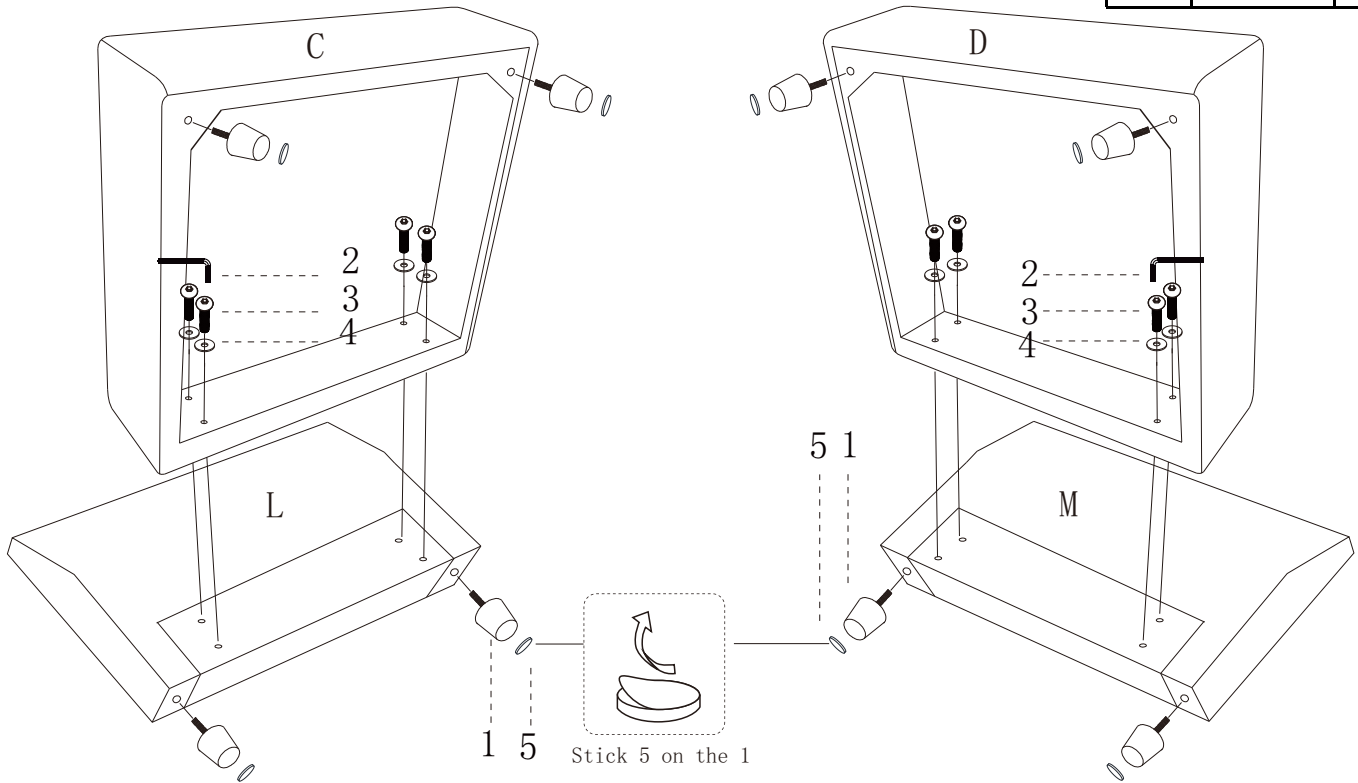





DIAGRAM 4

Connect the corner seat frame (Part E) and corner L backrest (Part J) with the screws (Hardware 3) and gaskets (Hardware 4) by hex key (Hardware 2).

2		1
3		8
4		8

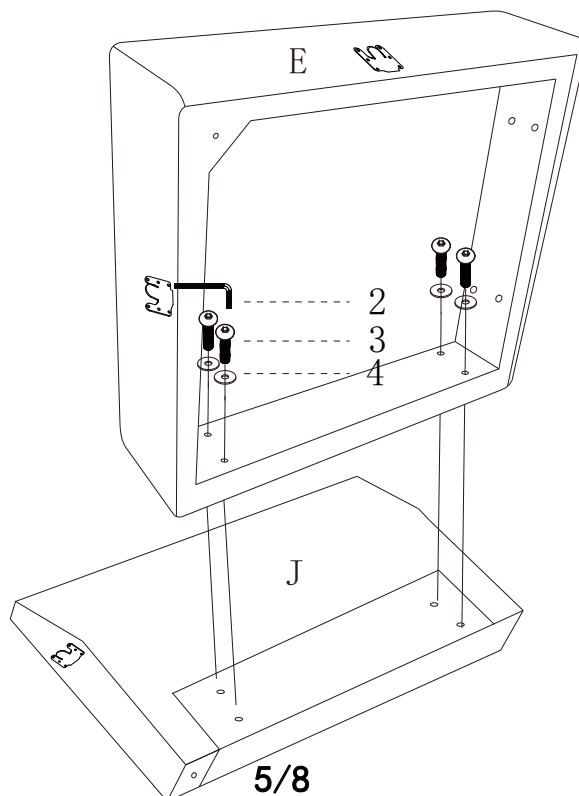







DIAGRAM 5

Connect the corner L backrest (Part J) to corner R backrest (Part K).
Connect the corner seat frame (Part E) and corner R backrest (Part K) with the screws (Hardware 3) and gaskets (Hardware 4) by hex key (Hardware 2).

Tighten 4 plastic legs (Part 1), and stick the feet decal (Part 5) onto each leg.

1		4
2		1
3		4
4		4
5		4

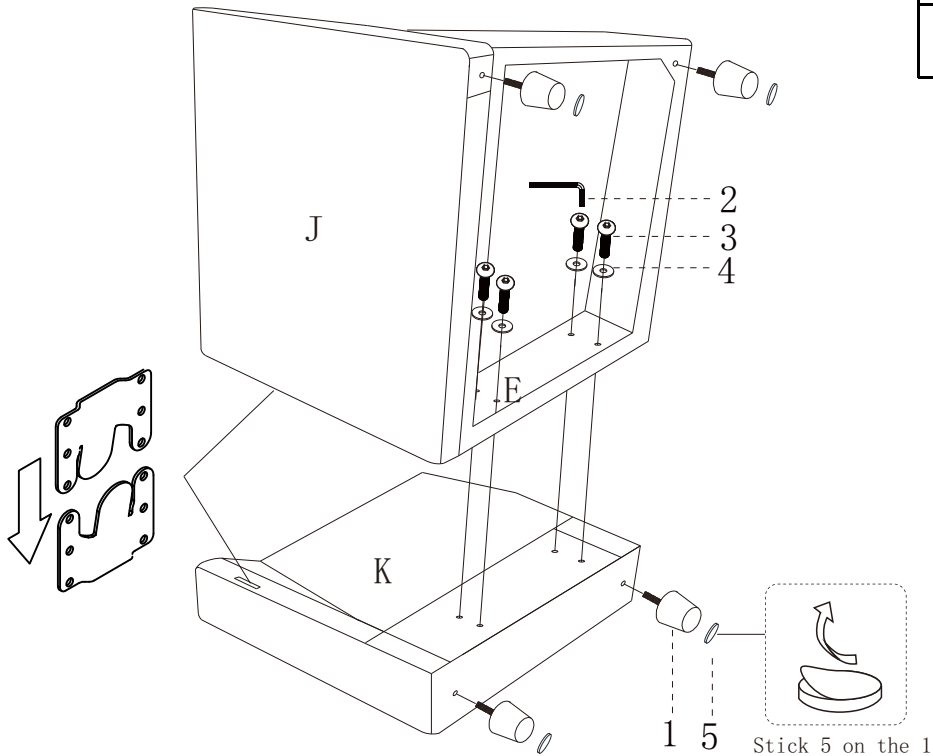

DIAGRAM 6

Connect the backrest (left) (Part L) to corner L backrest (Part J).
Connect the seat frame (left) (Part C) to corner seat frame (Part E).
Connect the backrest (right) (Part M) to corner R backrest (Part K).
Connect the seat frame (right) (Part D) to corner seat frame (Part E).

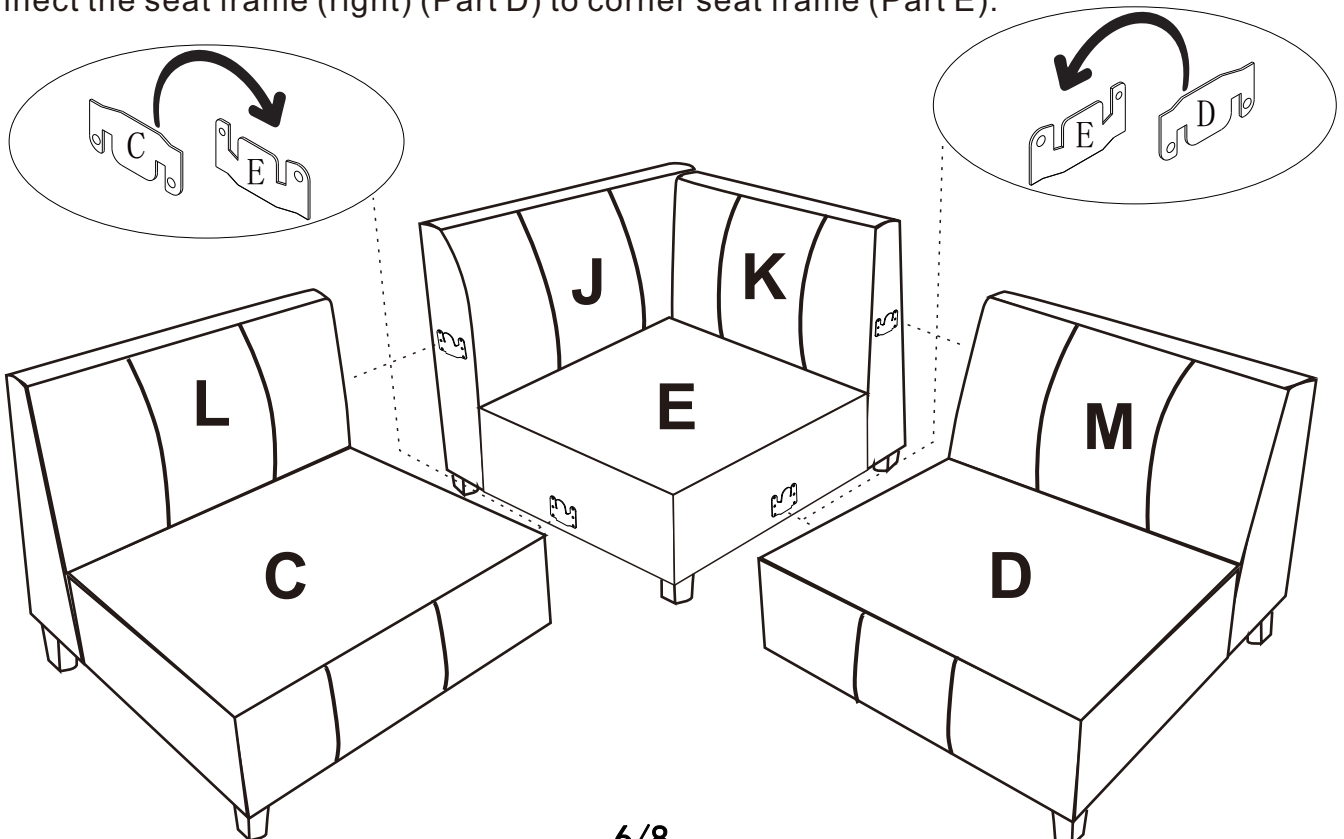
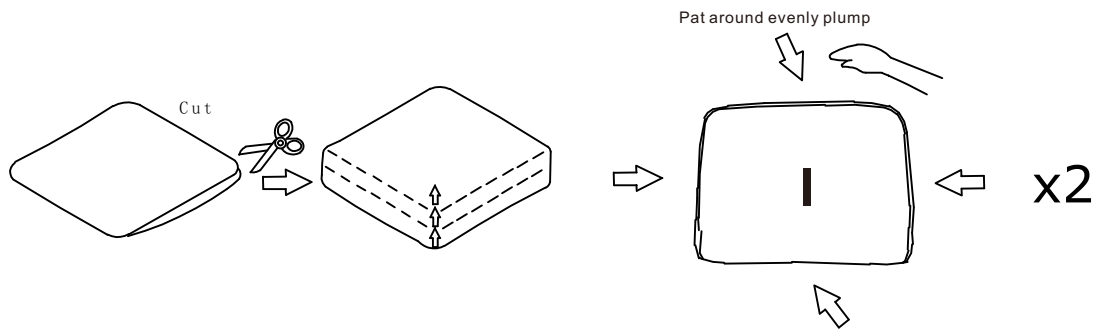
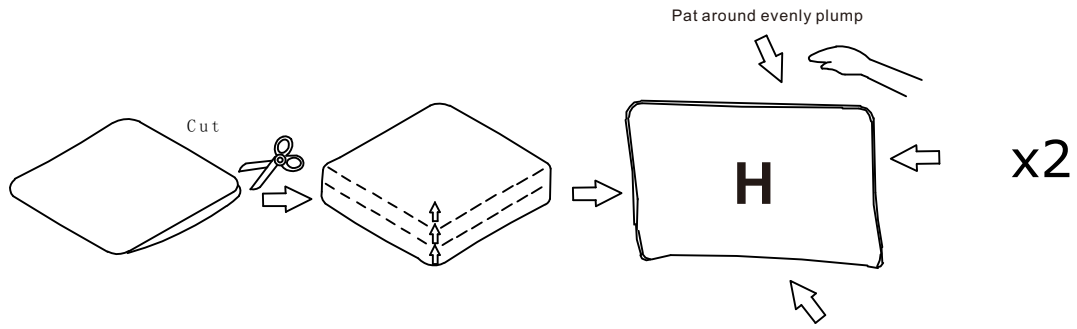

DIAGRAM 7

Remove the back cushions' plastic bags (Part H and Part I).



TIPS

1. Please do not open the compressed packages until your sofa frame is completely assembled.
2. Compressed cushions and back cushions need to be fully fulfilled within 72 hours for your perfect use.
3. Please keep children away from plastic bags or any small pieces of stuff.

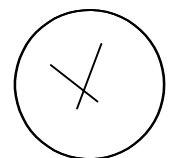
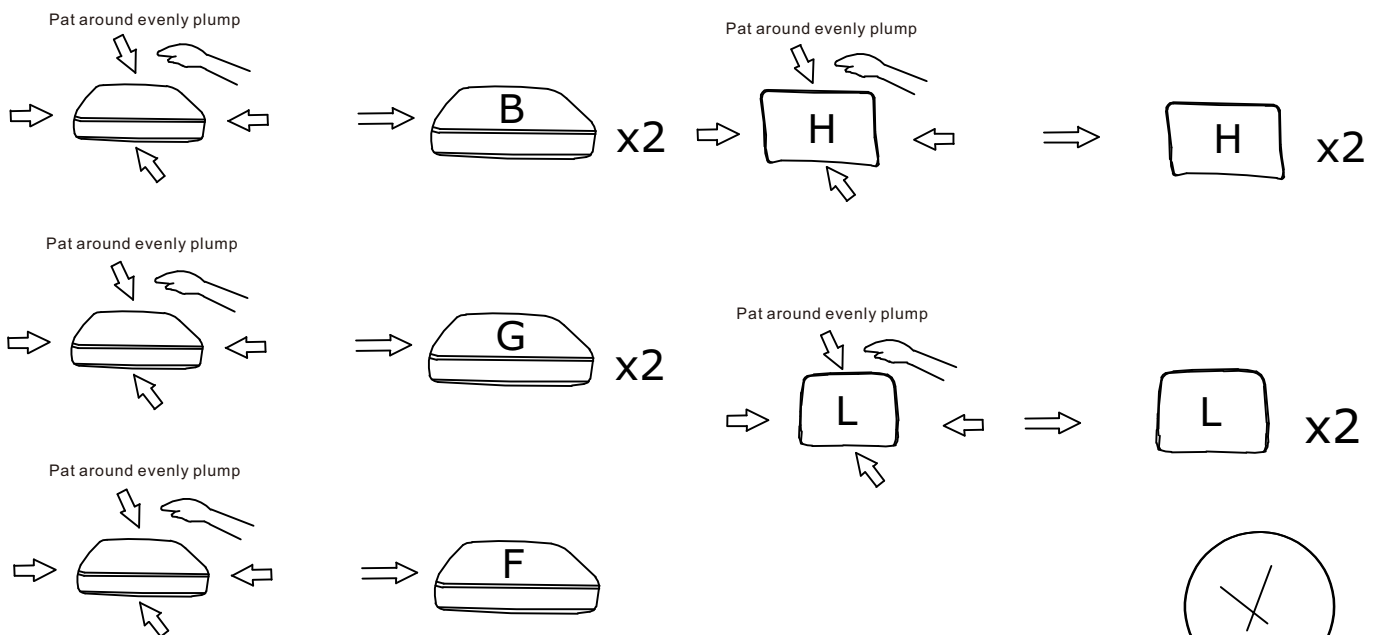

72h

DIAGRAM 8

Put the Ottoman cushions (Part B), Corner cushion (Part F), and Cushions (Part G) on the sofa.

Put the Back cushions (Part H) and Corner back cushions (Part I) on the sofa.

