

# Assembly Instructions

Caution: You must read this before you proceed.

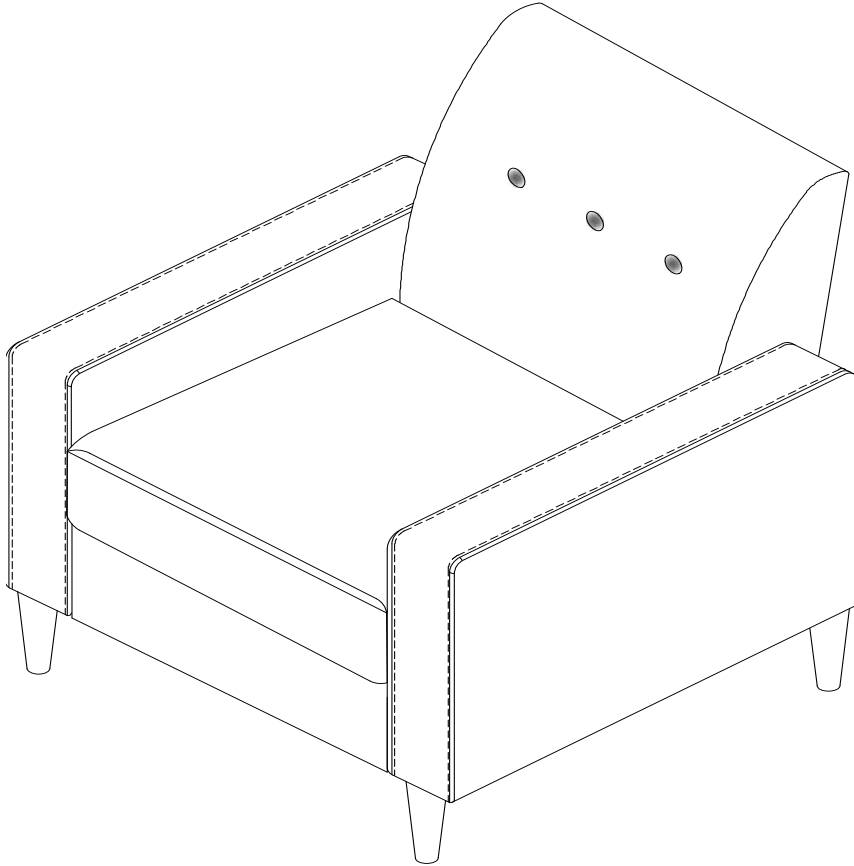



## CHAIR



### Parts List

Label	Picture	Description	Qty
A		Backrest	1
B		Seat Frame	1
C		Leg	4

# Hardware

Label	Picture	Description	Qty
①		Washer Ring	7
②		Spring Washer	2
③		Flat Washer	2
④		Bolt(M8*55MM)	2
⑤		Allen Wrench	1

# Assembly Preparation

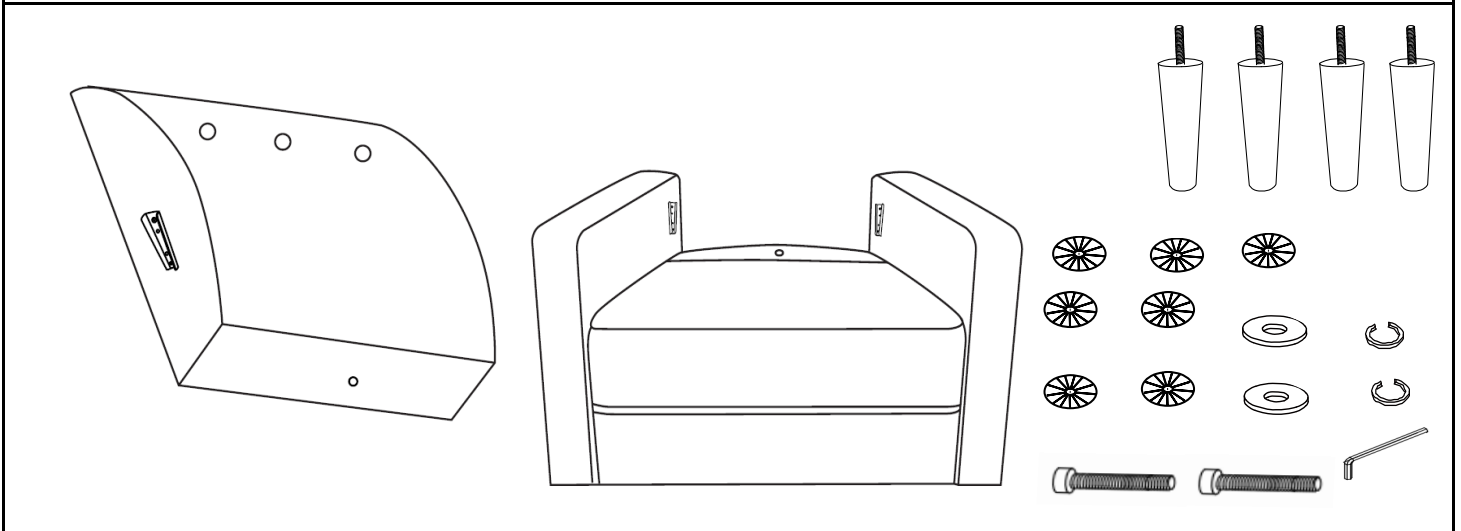

- Read instructions, cover to cover-



- Have 2 adults on hand for assembly-



- Do not assemble on flooring or carpet-



- Assemble on a clean non-marring surface (packing foam)-



- Save all packaging until finished-

# Assembly Steps

## OVERVIEW

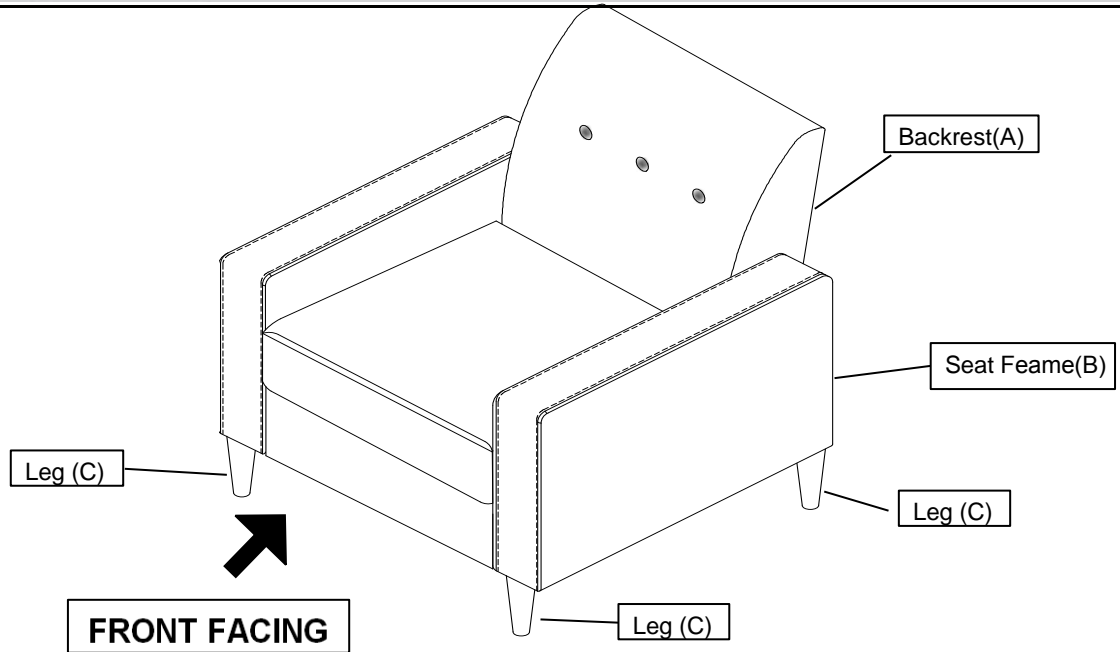

This CHAIR has multiple parts and may require up to 30 minutes to assemble. To give you an overview of the ARM CHAIR parts, the above picture is to help you put the various Chair parts into perspective. Please read through the instructions below to familiarise yourself with the parts and steps before assembly.

## Step 1

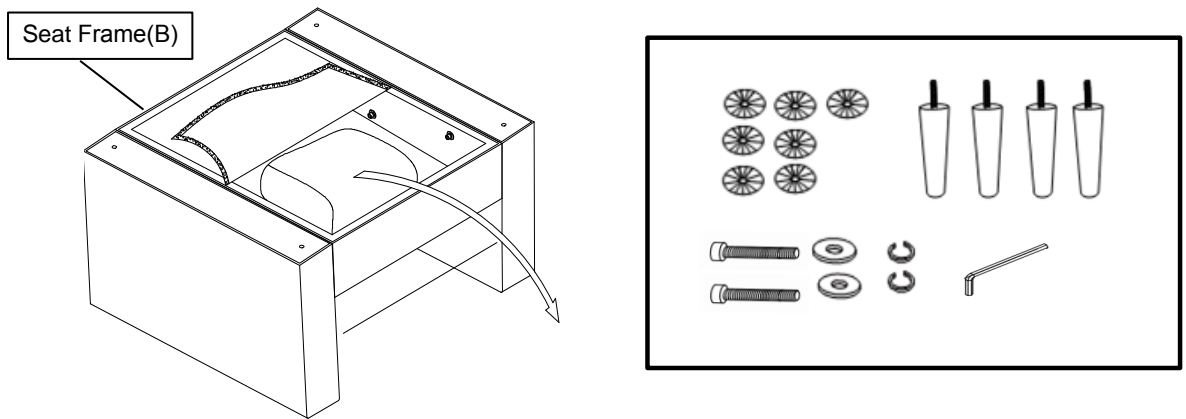

Position the Seat Frame(B) on its back, as shown. Unzip to open pouch and remove the 4 wooden legs and Hardware, close the pouch.

## Step 2

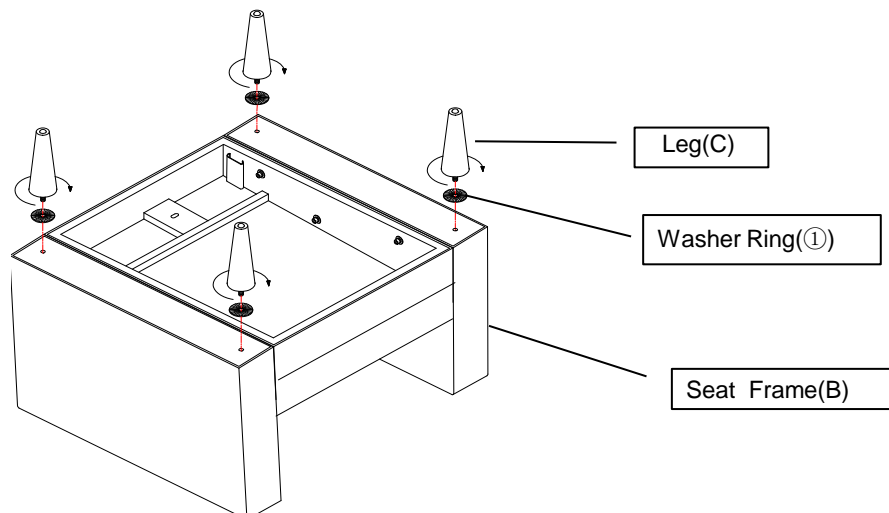

Install the Legs(C) into the bottom of the Seat Frame(B) by placing a Washer Ring(①) onto the threaded stem of the Legs.  
And then insert the threaded stem into the threaded mounting position at each Corner of the Bottom Seat Frame(B).  
Tighten by turning the Legs clockwise.  
Note: The use of Washer Ring(①) are OPTIONAL and are especially useful to help alleviate slight wobbles.  
Some Legs may need more than one Washer Ring(①) whilst some Legs may not need any. Position Sofa right side up and test for stability on a Level Surface.  
Add or remove Washer Ring(①) where needed to achieve stability.

**Step 3**

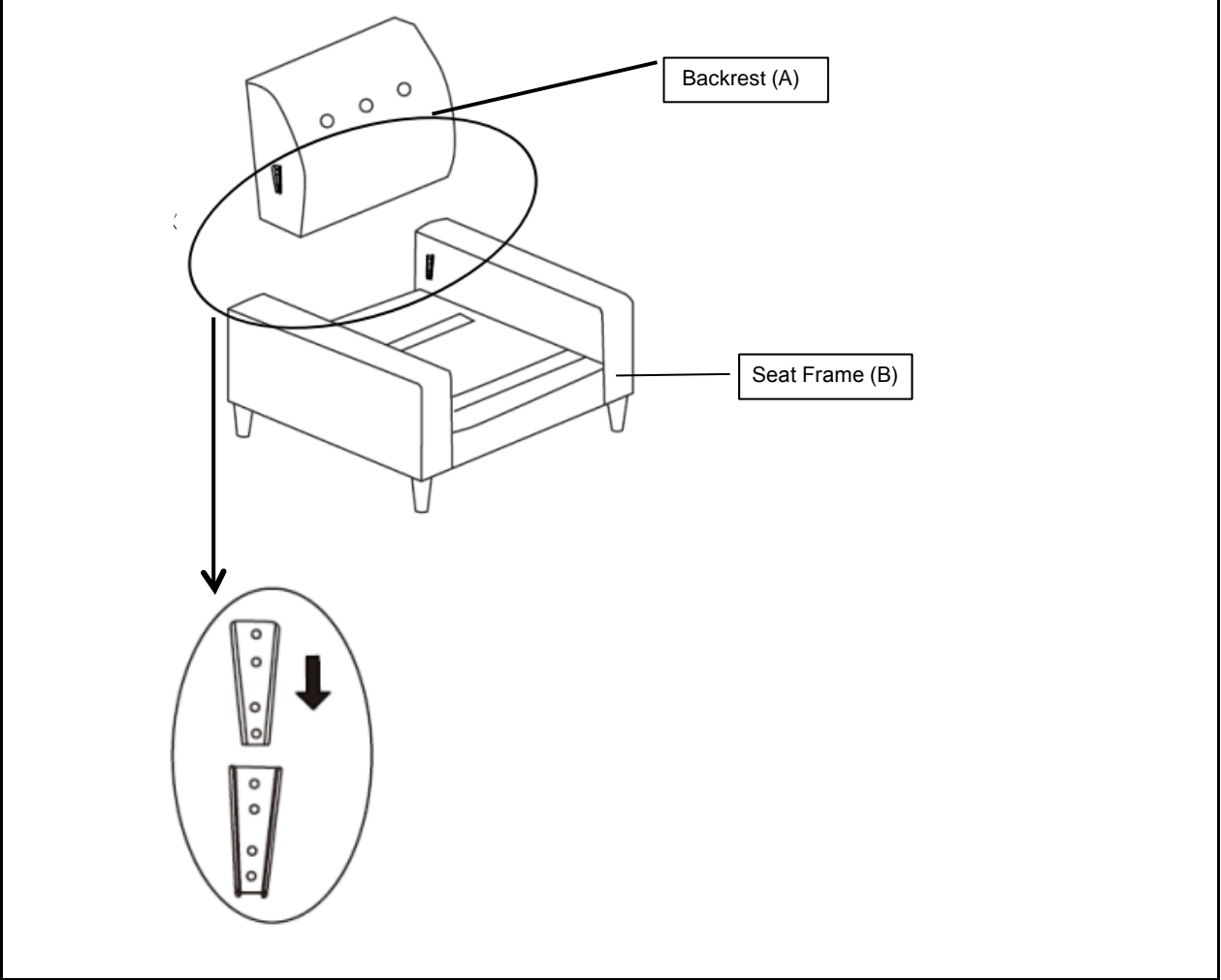

Attach the Backrest(A) to the Seat Frame(B) by pushing the Backrest (A) downwards until the Backrest(A) is fully slotted and locked into position with Seat Frame(B).

**Step 4**

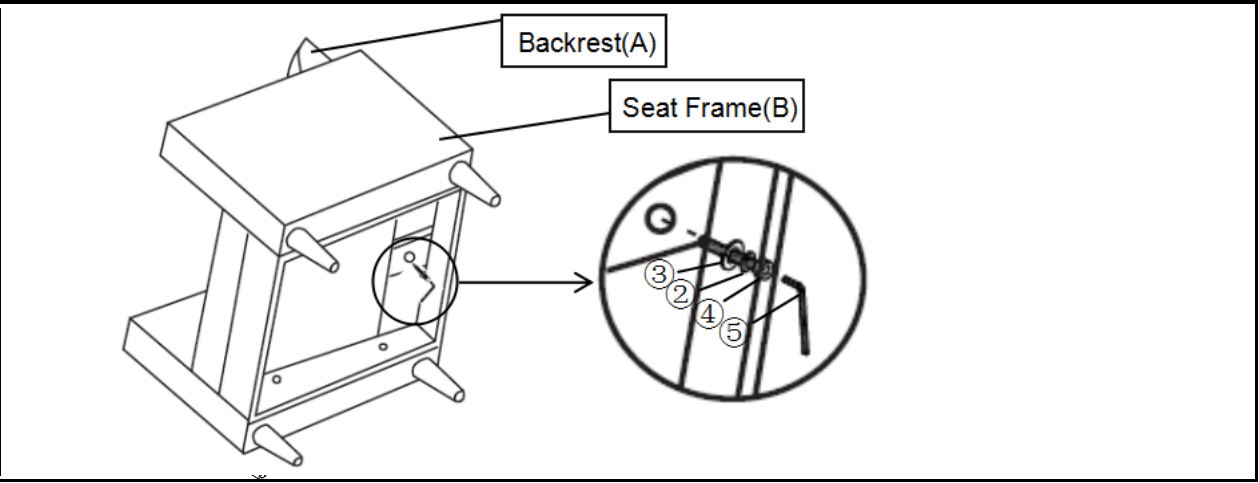

Lay the Chair on a flat surface as shown.  
Connect Backrest(A) with Seat Frame(B) using Bolt(④), Spring Washer(②) ,Flat Washer(③),  
with Allen Wrench(⑤) as shown.  
Turning clockwise until tight.

**Step 5**

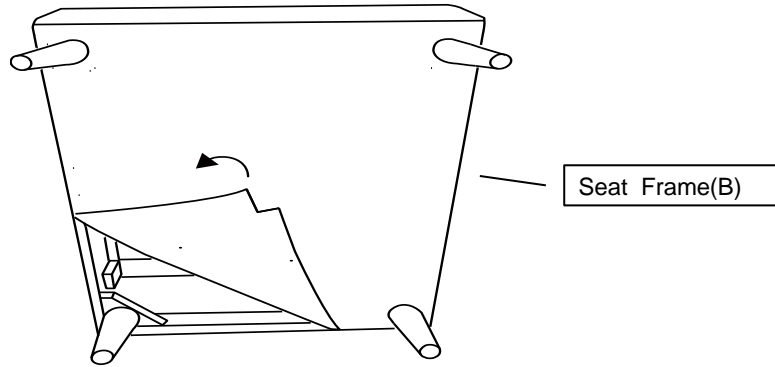

Cover the bottom of the Seat Frame (B) with the non-woven fabric.  
Smooth down the Magic Tape on all four sides of the Seat by hand.

**Step 6**

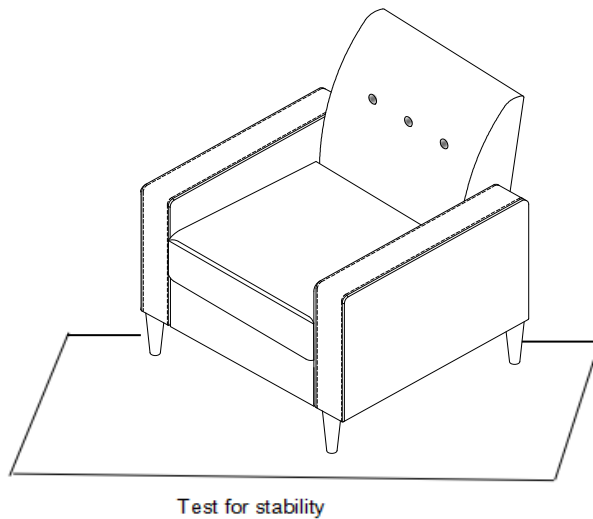

Add or remove Washer Ring(①) where needed to achieve stability  
Note:The use of Washer Ring(①) are OPTIONAL and is especially useful to help alleviate slight wobbleness. Some Legs may need more than one Washer Ring(①) whilst some Legs may not need any.  
Position Right arm sofa right side up and test for stability.

**Step 7**

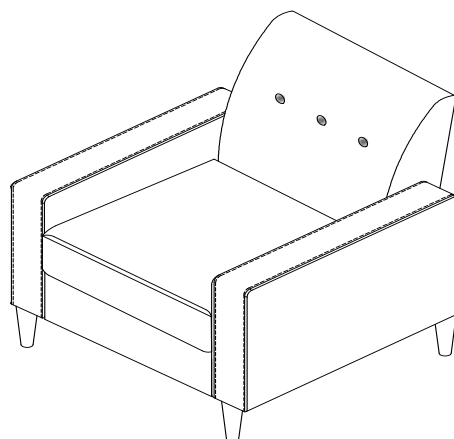

Your Chair is ready for use.  
This Chair can only be used on a flat, level surface.

## Care & Maintenance



- Furniture may scratch floors. We recommend using furniture pads to protect your floors.



- Do not put hot items directly on furniture surface.



- Do not clean furniture with harsh cleansers or polish.



- Do not place furniture under direct sunlight.



- Do not place furniture near heating or cooling vents.



- Do not write on furniture without a padded barrier to protect the surface.



- Do not place furniture outside . For indoor use only.



- Not for commercial use. For residential use only.



- Stains may be removed with mild soap solution and damp cloth.



- Children should not climb or jump on the furniture.



- Dust and pick-up spills using a clean, non-colored, lint-free cloth.