











# Assembly Instructions

**Caution : You must read this before you proceed**

## Care & Maintenance

- ⊘  ● Not for commercial use. For residential use only.
  - ✓  ● Furniture may scratch floors. We recommend using furniture pads to protect your floors.
  - ⊘  ● Do not put hot items directly on furniture surface.
  - ⊘  ● Do not clean furniture with harsh cleansers or polish.
  - ⊘  ● Do not place furniture under direct sunlight.
  - ⊘  ● Do not place furniture near heating or cooling vents.
  - ⊘  ● Do not write on furniture without a padded barrier to protect the surface.
  - ⊘  ● Do not place furniture outside . For indoor use only.
  - ⊘  ● Stains may be removed with mild soap solution and damp cloth.
  - ⊘  ● Children should not climb or jump on the furniture.
- 
- ✓  ● Dust and pick-up spills using a clean, non-colored, lint-free cloth.

**Please look in the carton for the hardware pack and legs.  
Sets often ship in multiple boxes and may arrive a day or two apart.**

# ACCENT CHAIR

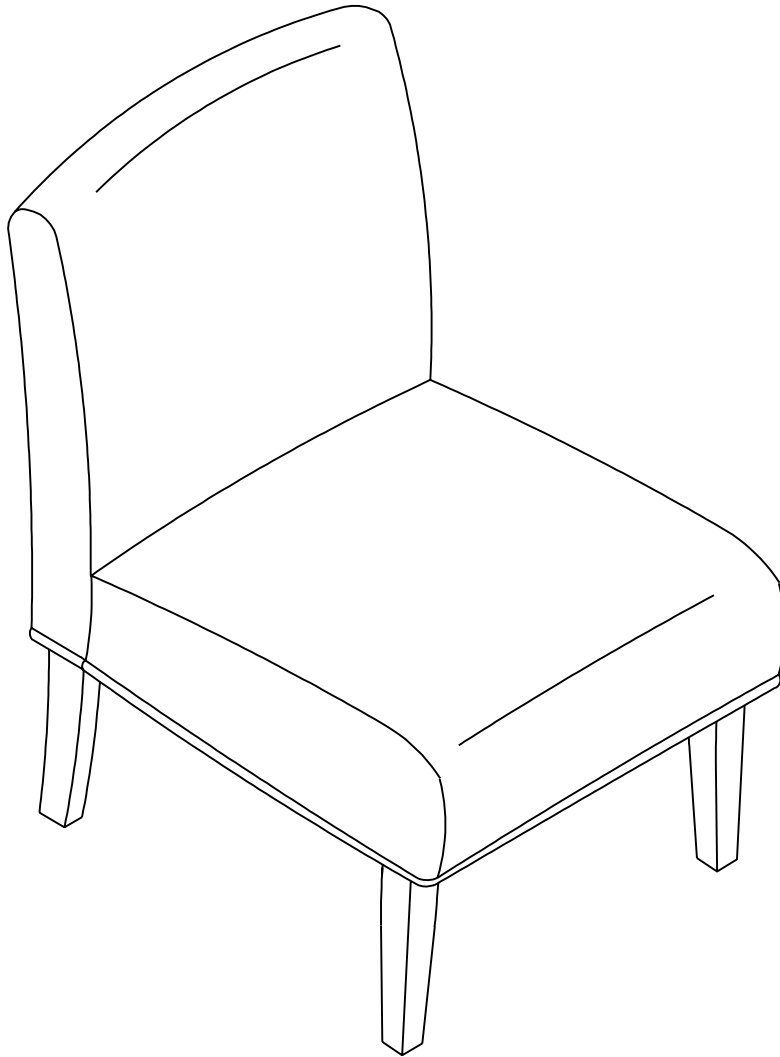

## Part List

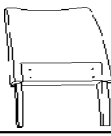
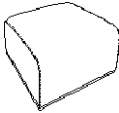
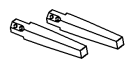
Label	Picture	Description	QTY
A		Chair Back	1
B		Chair Seat	1
C		Front leg	2

# Hardware

Label	Picture	Description	QTY
①		Bolt Set (M6x45mm)	5
②		Bolt Set (M6x60mm)	5
③		Allen Wrench (M4 Ball Long)	1

# Assembly Preparation

Before Beginning Assembly:

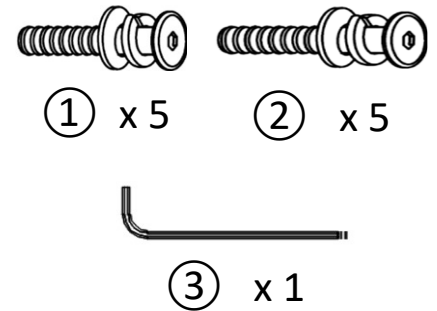
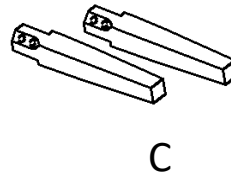
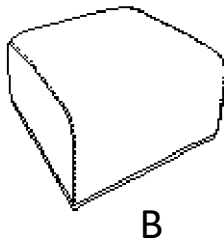
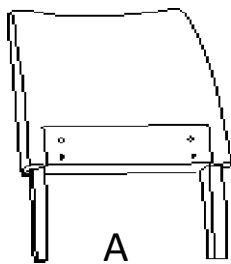

- Read instructions, cover to cover-



- Have 2 adults on hand for assembly-



- Do not assemble on flooring or carpet-



- Assemble on a clean non-marring surface (packing foam)-



- Save all packaging until finished-

# Assembly Steps

## Overview

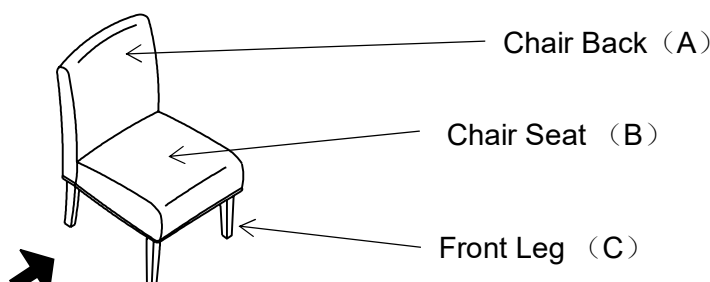

FRONT

This Accent Chair has multiple parts and may require up to 30 minutes to assemble. To give you an overview of the Accent Chair parts, the above picture is to help you put the various parts into perspective. Please read through the instructions below to familiarise yourself with the parts and steps before assembly.

## Step 1

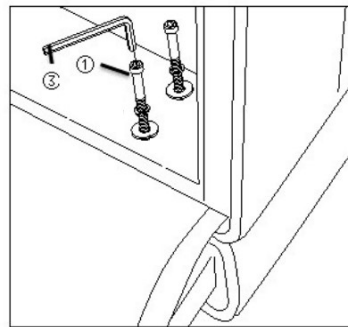
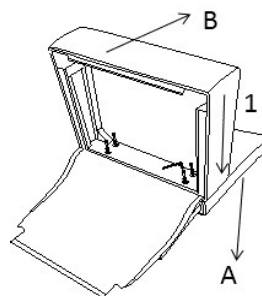

Put the Chair Back(A) onto a flat, clean, non-marring table. Align the mounting positions of the Chair Back(A) and Chair Seat(B). Use your left hand to push the seat floorwards, depicted by Arrow 1. This action helps to ensure the Chair Seat(B) is pressed towards to the Chair Back(A) with no gap between them. Using Bolt Set (①) with Allen Wrench (③) as shown above. **Do not fully tighten Bolts.**

## Step 2

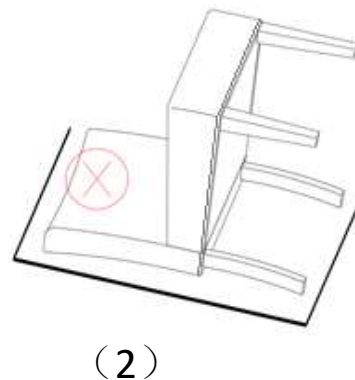
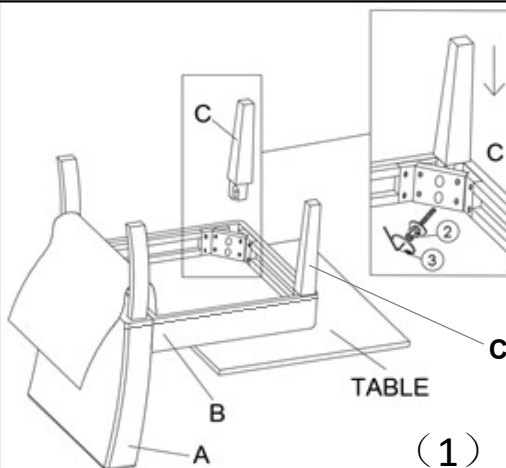

Place the Accent chair onto the side of a table as seen in picture 1. Position Front Leg (C) into Chair Seat(B) and attach using Bolt Set (②) with Allen Wrench(③). Repeat same step to attach Right Front Leg (C) to Chair Seat(B). Do not fully tighten Bolts.

**WARNING!! DO NOT POSITION THE FRONT LEG AS SHOWN IN PICTURE 2.**

**THIS PICTURE SHOWS THE CHAIR BACK STAYS AGAINST THE GROUND AND THE FRONT LEGS HORIZONTAL IN MIDAIR.**

**WARNING!! DO NOT OVER TIGHTEN.**

**OVER TIGHTENING COULD LEAD TO DAMAGE OF THE PRODUCT.**

**TIGHTEN ONLY UNTIL SECURE AND STABLE.**

### Step 3

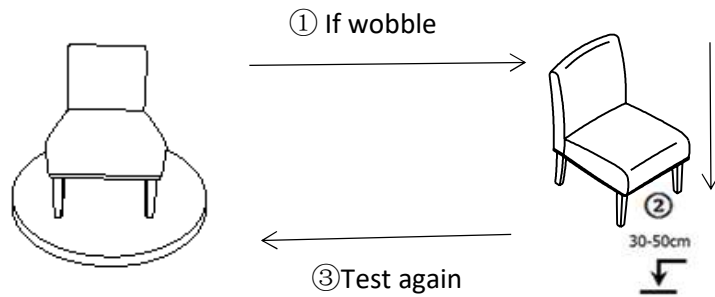

Place the Accent Chair on a Level Surface to see if it wobbles.

If it wobbles, lift the accent chair some 30cm to 50cm high from the ground.

Keep your feet and toes well away from the drop zone.

Drop the Chair freely and vertically with all four legs, hitting the ground, at the same time.

This Drop Test will help to ensure that all Bolts, and gaps reach full alignment status.

Test again for evenness on a Level Surface.

If no wobbles are found, proceed to tighten all the Bolts.

**Note: When tightening the Bolts, tighten sequentially.**

**Do not tighten any Bolt or fully and then move towards the next one.**

**This could cause the frame to warp.**

**If there are still wobbles, loosen the Bolts and execute this same drop test.**

**Note: If the accent chair is not stable, it could lead to damage to the product.**

### Step 4

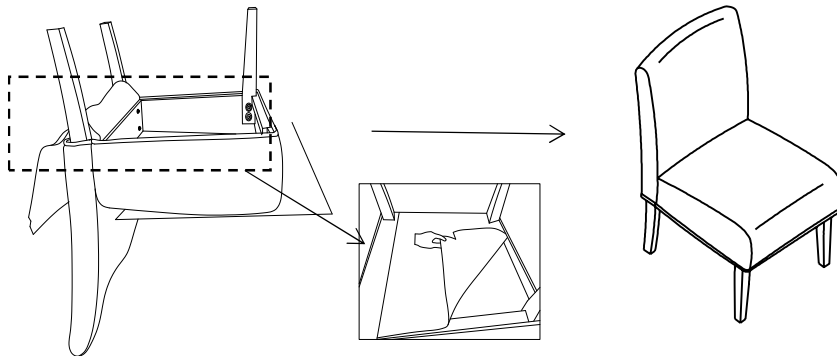

Place the Seat Base Cover back as shown in picture.

Smooth the Magic Tape down with your hand on all four sides at the edge of the seat.

Make sure all parts are connected and securely locked into position.

Then stand the Accent Chair up.

Your Accent Chair is ready for use.

**This Accent Chair can only be used on a flat, level surface.**

## Questions & Answers about Proposition 65

- What is Proposition 65?

Proposition 65 requires businesses to provide warnings to Californians about significant exposures to chemicals that cause cancer, birth defects or other reproductive harm. These chemicals can be in the products that Californians purchase, in their homes or workplaces, or that are released into the environment. By requiring that this information be provided, Proposition 65 enables Californians to make informed decisions about their exposures to these chemicals.

Proposition 65 also prohibits California businesses from knowingly discharging significant amounts of listed chemicals into sources of drinking water.

Proposition 65 requires California to publish a list of chemicals known to cause cancer, birth defects or other reproductive harm. This list, which must be updated at least once a year, has grown to include approximately 900 chemicals since it was first published in 1987.

- What types of chemicals are on the Proposition 65 list?

The list contains a wide range of naturally occurring and synthetic chemicals that include additives or ingredients in pesticides, common household products, food, drugs, dyes, or solvents. Listed chemicals may also be used in manufacturing and construction, or they may be byproducts of chemical processes, such as motor vehicle exhaust.

- What does a warning mean?

If a warning is placed on a product label or posted or distributed at a workplace, a business, or in rental housing, the business issuing the warning is aware or believes that it is exposing individuals to one or more listed chemicals.

By law, a warning must be given for listed chemicals unless the exposure is low enough to pose no significant risk of cancer or is significantly below levels observed to cause birth defects or other reproductive harm.

- Where can I get more information on Proposition 65?

If you have specific questions on the administration or implementation of Proposition 65, you can contact OEHHA's Proposition 65 program at [P65.Questions@oehha.ca.gov](mailto:P65.Questions@oehha.ca.gov), or by phone at (916) 445-6900.